

MAINTENANCE
USERS

Instructions and recommendations

Installer
User
Maintenance technician



MAGIS COMBO
4-6-9V2

1.045257ENG



INDEX

Dear Customer.....	4
General Recommendations.....	5
Safety symbols used.....	6
Personal protective equipment	6
1 Installing the indoor unit	7
1.1 Description of the product	7
1.2 Installation warnings	7
1.3 Main dimensions	11
1.4 Minimum installation distances	12
1.5 Antifreeze protection	12
1.6 Indoor unit connection unit	14
1.7 Hydraulic connection	14
1.8 Connecting the chiller line	15
1.9 Electrical connection	15
1.10 Room chrono-thermostats (Optional).....	20
1.11 MODBUS temperature and humidity room probes (Optional)	21
1.12 Remote zone control (Optional).....	22
1.13 Dominus (Optional).....	22
1.14 Humidistat ON/OFF (Optional).....	22
1.15 External temperature probe (Optional)	22
1.16 Temperature control setting.....	24
1.17 Immergas flue systems	25
1.18 Tables of resistance factors and equivalent lengths of “Green Range” flue system components.....	27
1.19 Outdoor installation in partially protected area	29
1.20 Concentric horizontal kit installation.....	31
1.21 Concentric vertical kit installation	32
1.22 Separator kit installation	35
1.23 C9 adaptor kit installation	36
1.24 Ducting of flues or technical slots.....	39
1.25 Configuration type B, open chamber and fan assisted for indoors.....	40
1.26 Flue exhaust to flue/chimney.....	40
1.27 Flues, chimneys and chimney caps	41
1.28 Water treatment plant filling	41
1.29 System filling.....	42
1.30 Filling the condensate drain trap	43
1.31 Gas system start-up.....	43
1.32 Operating limits.....	43
1.33 Commissioning the indoor unit (Ignition, only when paired with an outdoor unit)	44
1.34 Circulation pump	44
1.35 Kits available on request.....	46
1.36 Main components.....	47
2 Instructions for use and maintenance	48
2.1 General recommendations.....	48
2.2 Cleaning and maintenance.....	49
2.3 Control panel	50
2.4 System use.....	50
2.5 Fault and anomaly signals.....	54
2.6 Parameters and information menu.....	65
2.7 Indoor unit shutdown	70
2.8 Restore central heating system pressure.....	70
2.9 Draining the system	70

2.10	Emptying the D.H.W. circuit	70
2.11	Antifreeze protection	70
2.12	Cleaning the case	70
2.13	Permanent shutdown	70
2.14	Use of the remote zone panel (Optional).....	71
3	Instructions for maintenance and initial check.....	72
3.1	General recommendations.....	72
3.2	Initial check.....	73
3.3	Yearly appliance check and maintenance.....	73
3.4	Hydraulic diagram	75
3.5	Wiring diagram	76
3.6	System filter	84
3.7	Troubleshooting	85
3.8	Gas valve	86
3.9	Converting the heat generator to other types of gas.....	86
3.10	Fan speed calibration	87
3.11	Adjustment of the air-gas ratio	87
3.12	P.C.B. programming	88
3.13	"Chimneysweep" function.....	98
3.14	Pump anti-block function	98
3.15	Three-way anti-block system.....	98
3.16	Radiators antifreeze function	98
3.17	Photovoltaic function.....	99
3.18	Outdoor unit disable function.....	99
3.19	Preheating function	99
3.20	Diverter valve management (summer / winter).....	99
3.21	Automatic venting function	99
3.22	Screed heater function.....	100
3.23	Solar panels coupling function.....	101
3.24	Dehumidification function	101
3.25	Outdoor Unit Testmode Function	101
3.26	Outdoor Unit Pump Down Function	102
3.27	Puffer in preheating function	102
3.28	Night mode function	102
3.29	System setpoint correction function	102
3.30	Generator management	102
3.31	Casing removal	104
4	Technical data.....	107
4.1	Variable heat output	107
4.2	Combustion parameters.....	109
4.3	Technical data table	110
4.4	Magis Combo 4 V2 product fiche (in compliance with Regulation 811/2013)	111
4.5	Magis Combo 6 V2 product fiche (in compliance with Regulation 811/2013)	113
4.6	Magis Combo 9 V2 product fiche (in compliance with Regulation 811/2013)	115
4.7	Parameters for filling in the package fiche.....	117

Dear Customer

Congratulations for having chosen a top-quality Immergas product, able to assure well-being and safety for a long period of time. As an Immergas customer you can also count on a Qualified Authorised After-Sales Technical Assistance Centre, prepared and updated to guarantee constant efficiency of your appliance. Read the following pages carefully: you will be able to draw useful tips on the proper use of the device, compliance with which will confirm your satisfaction with the Immergas product.

For assistance and routine maintenance, contact Authorised Technical Service Centres: they have original spare parts and are specifically trained directly by the manufacturer.

Thermal systems must undergo periodic maintenance and scheduled checks of the energy efficiency in compliance with national, regional or local provisions in force.

The company **IMMERGAS S.p.A.**, with registered office in via Cisa Ligure 95 42041 Brescello (RE), declares that the design, manufacturing and after-sales assistance processes comply with the requirements of standard **UNI EN ISO 9001:2015**.

For further details on the product CE marking, request a copy of the Declaration of Conformity from the manufacturer, specifying the appliance model and the language of the country.

The manufacturer declines all liability due to printing or transcription errors, reserving the right to make any modifications to its technical and commercial documents without forewarning.



GENERAL RECOMMENDATIONS

This book contains important information for the:

Installer (section 1);

User (section 2);

Maintenance Technician (section 3).

- The user must carefully read the instructions in the specific section (section 2).
- The user must limit operations on the appliance only to those explicitly allowed in the specific section.
- **Every operation carried out on the heat pump (e.g. set up, inspection, installation and commissioning), must mandatorily be performed by authorised personnel alone and in possession of a technical engineering or professional degree qualifying them to perform these tasks. They must also have attended a refresher course acknowledged by competent authorities. This particularly applies to personal specialised in C.H. and air-conditioning systems and qualified electricians who, due to their specialised training, skills and experience are experts in the correct installation and maintenance of C.H., cooling and air-conditioning systems.**
- The appliance must be installed by qualified and professionally trained personnel.
- The instruction booklet is an integral and essential part of the product and must be given to the new user in the case of transfer or succession of ownership.
- It must be stored with care and consulted carefully, as all of the warnings provide important safety indications for installation, use and maintenance stages.
- In compliance with the legislation in force, the systems must be designed by qualified professionals, within the dimensional limits established by the Law. Installation and maintenance must be performed in compliance with the regulations in force, according to the manufacturer's instructions and by professionally qualified staff, meaning staff with specific technical skills in the plant sector, as provided for by Law.
- Improper installation or assembly of the Immergas device and/or components, accessories, kits and devices can cause unexpected problems for people, animals and objects. Read the instructions provided with the product carefully to ensure proper installation.
- This instructions manual provides technical information for installing Immergas products. As for the other issues related to the installation of products (e.g. safety at the workplace, environmental protection, accident prevention), it is necessary to comply with the provisions of the standards in force and the principles of good practice.
- All Immergas products are protected with suitable transport packaging.
- The material must be stored in a dry place protected from the weather.
- Damaged products must not be installed.
- Maintenance must be carried out by skilled technical staff. For example, the Authorised Service Centre that represents a guarantee of qualifications and professionalism.
- The appliance must only be destined for the use for which it has been expressly declared. Any other use will be considered improper and therefore potentially dangerous.
- If errors occur during installation, operation and maintenance, due to non-compliance with technical laws in force, standards or instructions contained in this booklet (or however supplied by the manufacturer), the manufacturer is excluded from any contractual and extra-contractual liability for any damages and the device warranty is invalidated.
- In the event of malfunctions, faults or incorrect operation, turn the appliance off and contact an authorised company (e.g. the Authorised Technical Assistance Centre, which has specifically trained staff and original spare parts). Do not attempt to modify or repair the appliance alone.

SAFETY SYMBOLS USED



GENERIC HAZARD

Strictly follow all of the indications next to the pictogram. Failure to follow the indications can generate hazard situations resulting in possible harm to the health of the operator and user in general, and/or property damage.



ELECTRICAL HAZARD

Strictly follow all of the indications next to the pictogram. The symbol indicates the appliance's electrical components or, in this manual, identifies actions that can cause an electrical hazard.



WARNING FOR INSTALLER

Read the instruction booklet carefully before installing the product.



LOW FLAMMABILITY MATERIAL

The symbol indicates that the appliance contains low flammability material.



WARNINGS

Strictly follow all of the indications next to the pictogram. Failure to follow the indications can generate hazard situations resulting in possible minor injuries to the health of both the operator and the user in general, and/or slight material damage.



ATTENTION

Read and understand the instructions of the appliance before carrying out any operation, carefully following the instructions given. Failure to observe the instructions may result in malfunction of the unit.



INFORMATION

Indicates useful tips or additional information.



EARTH TERMINAL CONNECTION

The symbol identifies the appliance's earth terminal connection point.



DISPOSAL WARNING

The user must not dispose of the appliance at the end of its service life as municipal waste, but send it to appropriate collection centres.

PERSONAL PROTECTIVE EQUIPMENT



SAFETY GLOVES



EYE PROTECTION



SAFETY FOOTWEAR

1 INSTALLING THE INDOOR UNIT

1.1 DESCRIPTION OF THE PRODUCT.

Magis Combo 4-6-9 V2 is a hybrid heat pump consisting of:

- Magis Combo V2 indoor unit (hereinafter it will only be referred to as indoor unit);
- UE Audax Pro 4-6-9 V2 outdoor condensing unit (hereinafter it will only be referred to as outdoor unit);

Magis Combo V2 is perfectly operational only if the two units are correctly powered and interconnected.

The indoor unit was designed solely for wall mounted installation for heating and air conditioning and to produce domestic hot water for domestic use and similar purposes.

For normal operation it must be paired with the following outdoor units:

- Audax Pro 4 V2 outdoor condensing unit;
- Audax Pro 6 V2 outdoor condensing unit;
- Audax Pro 9 V2 outdoor condensing unit.

Accordingly it is necessary to comply with all of the rules regarding safety and the use of both appliances.

1.2 INSTALLATION WARNINGS



Operators who install and service the appliance must wear the personal protective equipment required by applicable law.



The place of installation of the appliance and relative Immergas accessories must have suitable features (technical and structural), such as to allow for (always in safe, efficient and comfortable conditions):

- installation (according to the provisions of technical legislation and technical regulations);
- maintenance operations (including scheduled, periodic, routine and special maintenance);
- removal (to outdoors in the place for loading and transporting the appliances and components) as well as the eventual replacement of those with appliances and/or equivalent components.



By varying the type of installation the classification of the indoor unit also varies, precisely:

- **Type B₂₃ o B₅₃** indoor unit if installed using the relevant terminal for air intake directly from the room in which the boiler has been installed.
- **Type C indoor unit** if installed using concentric pipes or other types of pipes envisioned for the sealed chamber boiler for intake of air and expulsion of flue gas.



Only a professionally enabled company is authorised to install Immergas appliances.



Installation must be carried out according to regulation standards, current legislation and in compliance with local technical regulations and the required technical procedures.



It is not permitted to install boilers that are removed and decommissioned from other systems.

The manufacturer declines all liability for damages caused by boilers removed from other systems or for any non-conformities of such equipment.



The wall surface must be smooth, without any protrusions or recesses enabling access to the rear part. They are not designed to be installed on plinths or floors (Fig. 1).

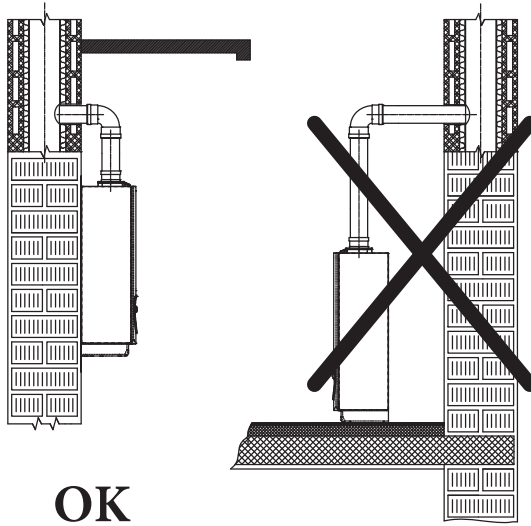

OK

1



The appliance operates with R32 refrigerant gas.

This gas is ODOURLESS.



Pay the utmost attention

Strictly follow the instruction handbook of the Audax Pro V2 outdoor condensing unit before installation and any type of operation on the cooling line.



R32 refrigerant gas belongs to the low flammability refrigerant category: class A2L according to standard ISO 817. It guarantees high performance with low environmental impact. The new gas reduces the potential environmental impact by one third compared to R410A, having less effect on global warming (GWP 675).



Check the environmental operating conditions of all parts relevant to installation, referring to this booklet.



Before installing the appliance, ensure that it is delivered in perfect condition; if in doubt, contact the supplier immediately. Packing materials (staples, nails, plastic bags, polystyrene foam, etc.) constitute a hazard and must be kept out of the reach of children.

If the appliance is installed inside or between cabinets, ensure sufficient space for routine servicing; for minimum installation distances, see Fig. 3.



If installing a kit or servicing the appliance, always empty the system's domestic hot water circuit first so as not to compromise the appliance's electrical safety (Parag. 2.9, 2.10).

Always disconnect the appliance from voltage and, depending on the type of operation, decrease the pressure and/or bring it to zero in the gas and DHW circuits.



Keep all flammable objects away from the appliance (paper, rags, plastic, polystyrene, etc.).



Do not put household appliances under the indoor unit as they could be damaged if the safety valve trips or if the hydraulic fittings leak. Otherwise, the manufacturer cannot be held liable for any damage to the household appliances.



For the aforementioned reasons, we recommend not placing furnishings, furniture, etc. under the indoor unit.

 Any modification to the appliance that is not explicitly indicated in this section of the booklet is forbidden.

 In the event of malfunctions, faults or incorrect operation, turn the appliance off and contact an authorised company (e.g. the Authorised Technical Assistance Centre, which has specifically trained staff and original spare parts).
Do not attempt to modify or repair the appliance alone.

Installation standards

 This indoor unit can be installed outdoors in a partially protected area.
A partially protected area is one in which the indoor unit is not exposed to the direct action of the weather (rain, snow, hail, etc.).

 This type of installation is possible when permitted by the laws in force in the appliance's country of destination.

 **Installation of gas appliances, flue exhaust pipes and combustion air intake pipes is forbidden in places with a fire risk (for example: garages, closed parking stalls), and in potentially dangerous places.**

 **Do not install on the vertical projection of hobs.**

 **Do not install in places/rooms that constitute public areas of apartment buildings, internal stairways or other escape routes (e.g. floor landings, entrance halls, etc.).**

 **Installation is also forbidden in places/rooms that constitute public areas of apartment buildings such as cellars, entrance halls, attics, lofts, etc., unless otherwise provided for by local regulations in force.**

 **In any configuration do not install the indoor unit and outdoor unit at altitudes above 2000 m.**

 **To prevent electrocution, fire or injury, always switch off the unit, disable the protective switch and, if smoke escapes or if the unit is extremely noisy, contact the Authorised After-Sales Technical Assistance Centre.**

 **Pay attention not to generate sparks as follows:**
– Do not remove the fuses while the unit is on.
– Do not unplug the unit while it is on.
It is recommended to install the outlet high up. Lay the cables in such a way that they do not get tangled.

 **Wall mounting of the indoor unit must guarantee stable and efficient support for the generator.**

The plugs (standard supply) are only to be used to fix the indoor unit to the wall; they only ensure adequate support if inserted correctly (according to technical standards) in walls made of solid or semi-hollow brick or block. In the case of walls made from hollow brick or block, partitions with limited static properties, or in any case walls other than those indicated, a static test must be carried out to ensure adequate mount.



This indoor unit is used to heat water to below boiling temperature in atmospheric pressure.



They must be connected to a central heating system and domestic hot water circuit suited to their performance and capacity.



**The appliance is built to also operate in cooling mode.
If cold water production, during summer, could interfere and damage the central heating only systems, necessary precautions must be taken to prevent that an unintentional production of cold water enters the heating only system.**



Failure to comply with the above implies personal responsibility and invalidates the warranty.

1.3 MAIN DIMENSIONS

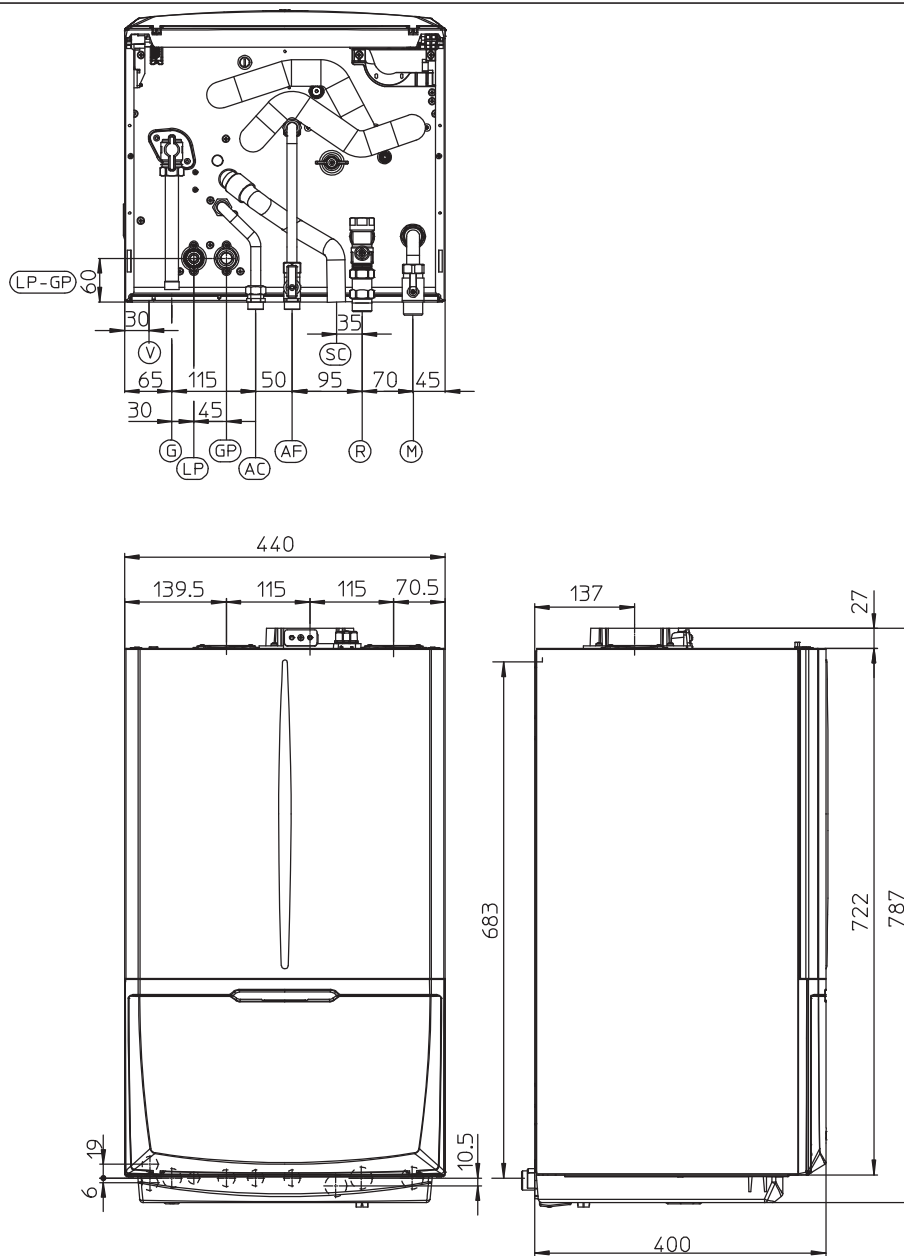

2

Height (mm)		Width (mm)		Depth (mm)
787		440		400
CONNECTIONS				
LINE CHILLER LINE		GAS	DOMESTIC HOT WATER	SYSTEM
LP	GP	G	AC - AF	R - M
SAE 1/4"	SAE 5/8"	3/4"	1/2"	3/4"

Key (Fig. 2):

- V - Electrical connection
- G - Gas supply
- AC - Domestic hot water outlet
- AF - Domestic hot water inlet
- SC - Condensate drain (minimum internal diameter \varnothing 13 mm)
- R - System return
- M - System flow
- LP - Chiller line - liquid phase
- GP - Chiller line - gaseous phase

INSTALLER

USER

MAINTENANCE TECHNICIAN

TECHNICAL DATA

1.4 MINIMUM INSTALLATION DISTANCES

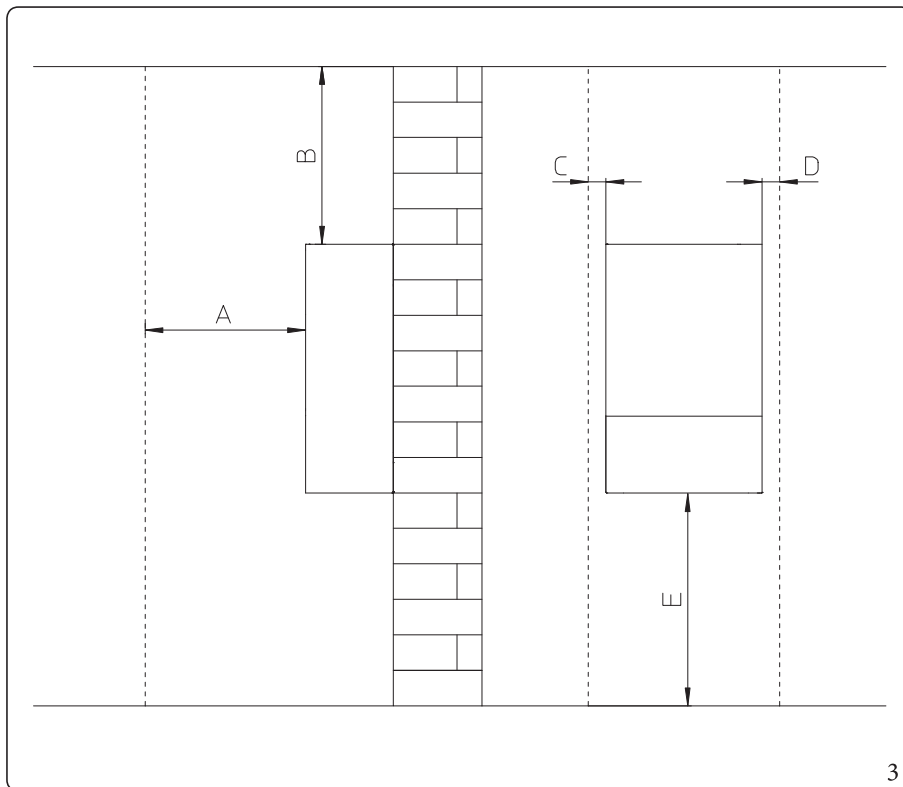

Key (Fig. 3):

- A - 450 mm
- B - 350 mm
- C - 30 mm
- D - 30 mm
- E - 350 mm

1.5 ANTIFREEZE PROTECTION

Minimum temperature -5°C

The indoor unit comes standard with an anti-freeze function that activates the outdoor unit when the temperature of the water inside of it falls below 4°C.



In these conditions, the indoor unit is protected against freezing up to an ambient temperature of -5°C.

Minimum temperature -15°C



If the indoor unit is installed in a place where the temperature drops below -5°C, the appliance can freeze.

To prevent the risk of freezing follow the instructions below:

- protect the central heating circuit from freezing by inserting a good-quality antifreeze liquid into this circuit, which is specially suited for central heating systems and which is manufacturer guaranteed not to cause damage to the heat exchanger or other components of the indoor unit. The antifreeze liquid must not be harmful to one's health. The instructions of the manufacturer of this liquid must be strictly followed regarding the necessary percentage with respect to the minimum temperature at which the system must be kept.
- the materials used for the central heating circuit of Immergas indoor unit resist ethylene and propylene glycol based antifreeze liquids (if the mixtures are prepared perfectly).
- an aqueous solution must be made with potential pollution class of water 2 (EN 1717:2002 or local standards in force).



The excessive use of glycol could jeopardise the proper functioning of the appliance.



For life and possible disposal, follow the supplier's instructions.

- Protect the domestic hot water circuit against freezing by using an accessory that is supplied on request (antifreeze kit) comprising two electric heating elements, the relevant wiring and a control thermostat (carefully read the installation instructions contained in the accessory kit pack).



In these conditions, the indoor unit is protected against freezing up to a temperature of -15°C.

Indoor unit anti-freeze protection (both -5°C and -15°C) is only ensured if:

- indoor unit and outdoor unit are properly connected to each other and to the electrical power supply circuits;
- the units are continuously powered;
- the indoor unit is not in “off” mode;
- the units are not in anomaly (Parag. 2.5);
- the antifreeze unit and/or kit essential components are not faulty.

The warranty does not cover damage due to interruption of the electrical power supply and failure to comply with that stated on the previous page.



If the indoor unit is installed in places where the temperature drops below 0°C, the domestic hot water connection pipes must be insulated.



The antifreeze systems described in this chapter are only to protect the indoor unit. The presence of these functions and devices does not exclude the possibility of parts of the circuits outside the indoor unit from freezing.

1.6 INDOOR UNIT CONNECTION UNIT

- The hydraulic connection unit is standard supplied with Magis Combo V2. Make the hydraulic connection as shown below, making sure to protect the system flow and return pipes with their supplied insulating sheaths.
- The R32 circuit wall connection unit is supplied as an extra kit. Connect the circuit, following the instructions provided in the outdoor unit instructions booklet.

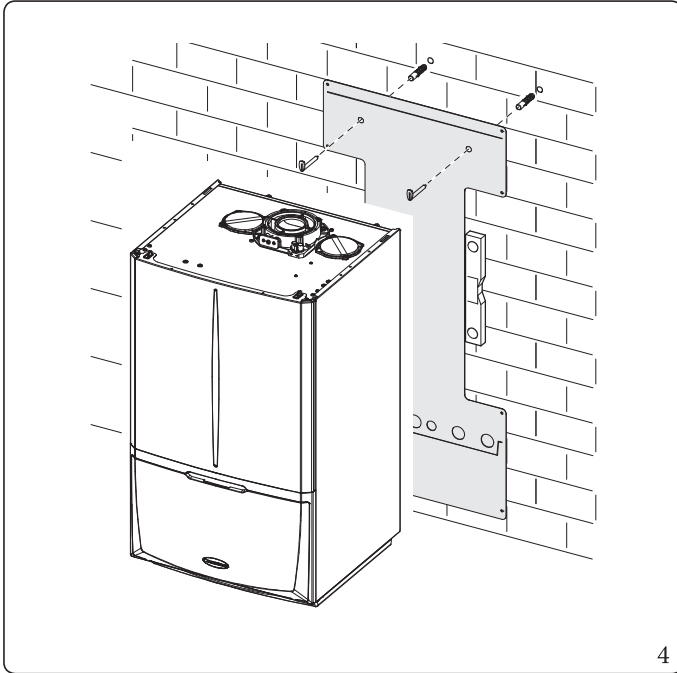

The hydraulic connection kit includes (Fig. 4):

- N°2 - Adjustable expansion bolts
 - N°2 - Indoor unit support hooks
 - N°1 - Gas supply pipe Ø 18 (G)
 - N°1 - 1/2" cold water inlet pipe (AF)
 - N°1 - 1/2" hot water inlet pipe (AC)
 - N°1 - 1/2" ball valve (AF)
 - N°1 - 3/4" system return pipe (R)
 - N°1 - 3/4" system flow pipe (M)
 - N°1 - 3/4" ball valve (M)
 - N°3 - Insulating sheath for system pipes (R - M)
 - N°1 - 1/2" telescopic fitting (AC)
 - N°1 - 3/4" telescopic fitting (R)
- Gaskets, screws and seal O-Ring

The R32 circuit wall connection kit (optional) includes:

- N°1 - SAE 1/4" liquid phase chiller line pipe (LP)
- N°1 - SAE 5/8" gaseous phase chiller line pipe (GP)

Already installed on the module:

- N°1 - Gas cock
- N°1 - System shut-off cock with 3/4" filter (R)

1.7 HYDRAULIC CONNECTION



In order not to void the warranty, before making indoor unit connections, carefully clean the heating system (pipes, radiators, etc.) with special pickling or de-scaling products to remove any deposits that could jeopardise proper hydronic module operation.

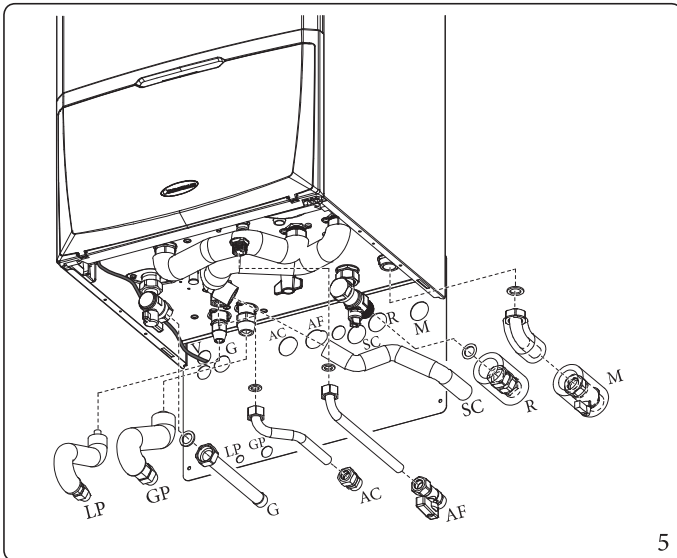

Key (Fig. 5):

- V - Electrical connection
- G - Gas supply
- AC - Domestic hot water outlet
- AF - Domestic hot water inlet
- SC - Condensate drain (minimum internal diameter Ø 13 mm)
- R - System return
- M - System flow
- LP - Chiller line - liquid phase
- GP - Chiller line - gaseous phase

3 bar safety valve

The drain of the safety valve must always be properly conveyed to a draining funnel; consequently, in case of valve operation, the leaked fluid will end up in the sewer system.

Condensate drain

To drain the condensate produced by the appliance, it is necessary to connect to the drainage system by means of acid condensate resistant pipes, with an internal \varnothing of at least 13 mm.

The system connecting the appliance to the drainage system must be carried out in such a way as to prevent occlusion and freezing of the liquid contained in it.

Before appliance ignition, ensure that the condensate can be correctly removed. After first ignition, check that the drain trap is filled with condensate.

Also, comply with national and local regulations on discharging waste waters.

In the event condensate is not discharged into the wastewater drainage system, a condensate neutraliser must be installed to ensure compliance with the parameters established by the legislation in force.

A treatment of the heating and water system water is required, in compliance with the technical standards in force, in order to protect the system and the appliance from deposits (e.g. scale), slurry or other hazardous deposits.

In order not to void the heat exchanger warranty, you are required to comply with what has been prescribed (Par. 1.28).

Water connections must be made in a rational way using the couplings on the indoor unit template.



The manufacturer declines all liability in the event of damage caused by the installation of an automatic filling system.

In order to meet the system requirements established by EN 1717 in terms of pollution of drinking water, we recommend installing the IMMERGAS anti-backflow kit to be used upstream of the cold water inlet connection of the indoor unit. We also recommend using category 2 heat transfer fluid (ex: water + glycol) in the internal unit primary circuit (heating and/or cooling circuit), as defined in standard EN 1717.



To preserve the duration of appliance efficiency features, in the presence of water whose features can lead to the deposit of lime scale, installation of the "polyphosphate dispenser" kit is recommended.



If you are using one or more booster pumps it is essential to install a hydraulic separator (not supplied by Immergas) downstream of the indoor unit.

1.8 CONNECTING THE CHILLER LINE

As far as connecting the cooling line is concerned, all the instructions contained in the outdoor unit instructions booklet must be followed.

Make the connections directly on the indoor unit couplings, or use the rear outlet kit (optional).

1.9 ELECTRICAL CONNECTION



Disconnect power to the unit before making any electrical connections.

The appliance has an IPX4D degree of protection; electrical safety of the appliance is achieved only when it is properly connected to an efficient earthing system, as specified by current safety standards.



The manufacturer declines any responsibility for damage or physical injury caused by failure to connect the indoor unit to an efficient earthing system or failure to comply with the IEC reference standards.



Connection cables must respect the prearranged routes.

Use 3 clips (c) (not supplied) to group the individual cables (max. 1.5 mm² into the lower terminal board).

Use the specific fairleads (d) on the left side, making sure to put at most 2 multi-polar cables (max 3 x 1 mm²) in each fairlead.

The figure 6 shows cables in a hypothetical connection. To make the connections based on your own requirements, see the instructions below.

Open the control panel connections compartment (Fig. 6).

To carry out electrical connections, all you have to do is open the connections compartment as follows.

1. Remove the front panel.
2. Disassemble the cover.
3. Loosen the screws (a).
4. Remove the cover (b) from the control panel (c).

At this point, you can access the terminal board.

Also ensure that the electrical installation corresponds to maximum absorbed power specifications as shown on the indoor unit data-plate.

Indoor units are supplied complete with a “Y” type power supply cable H 05 VVF 3 x 0,75 mm² without plug.



The power supply cable must be connected to a 230V ±10% / 50Hz mains supply respecting L-N polarity and earth connection; this network must also have a multi-pole circuit breaker with class III overvoltage category in compliance with installation regulations.



To protect from possible dispersions of DC voltage, it is necessary to provide a type A differential safety device.



If the power cable is damaged, contact a qualified company (e.g. the Authorised Technical Assistance Centre) for its replacement to avoid a hazard.

The power cable must follow the prescribed route (Par. 1.7); avoiding contact with the side of the frame.

If the fuses on the circuit boards need to be replaced, this must also be done by qualified personnel: use a F3.15A H250V fuse on the P.C.B. For the main power supply to the appliance, never use adapters, multiple sockets or extension leads.

Make the various electrical connections according to your needs (Fig. 7, 8):

Outdoor unit electrical connection

The indoor unit must be coupled to an outdoor unit by connecting terminals F1 and F2 as shown in the wiring diagram (Fig. 8). The outdoor unit is powered at 230 V, regardless of the indoor unit.

Configure the indoor unit parameters as indicated in paragraph (Parag. 3.12).

Photovoltaic system installation

Connecting the product to a photovoltaic system enhances use of the outdoor unit when the photovoltaic panels are operating. Carry out the connection as indicated (Fig. 7).

Dehumidifiers

Carry out the connection as indicated (Fig. 8). To complete the connection operations, insert the 2-relay Board optional kit.



**It is compulsory to set up separate lines with different power supply voltages, particularly it is essential to separate the very low voltage connections from the 230 V ones.
No product pipes must ever be used to earth the electric system or telephone lines.
Ensure elimination of this risk before making the indoor unit electrical connections.**



The indoor unit can be electrically connected to outdoor units with very low voltage safety circuits (SELV)

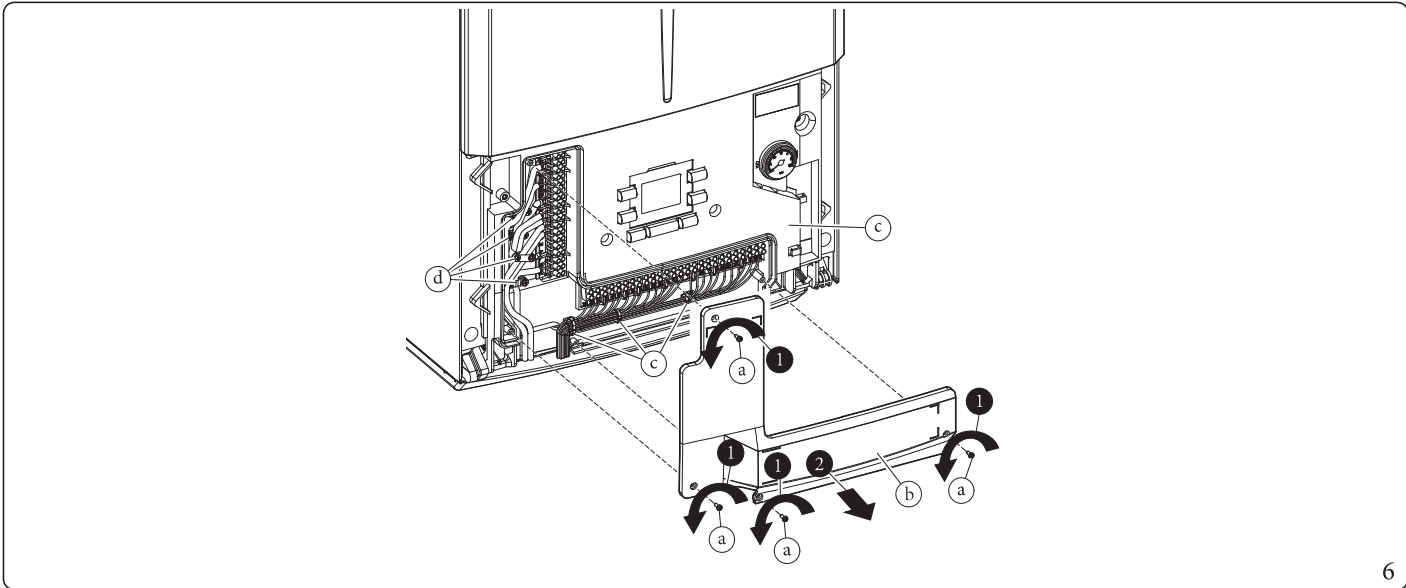

6

INSTALLER

USER

MAINTENANCE TECHNICIAN

TECHNICAL DATA

Horizontal terminal block electrical connection diagram.

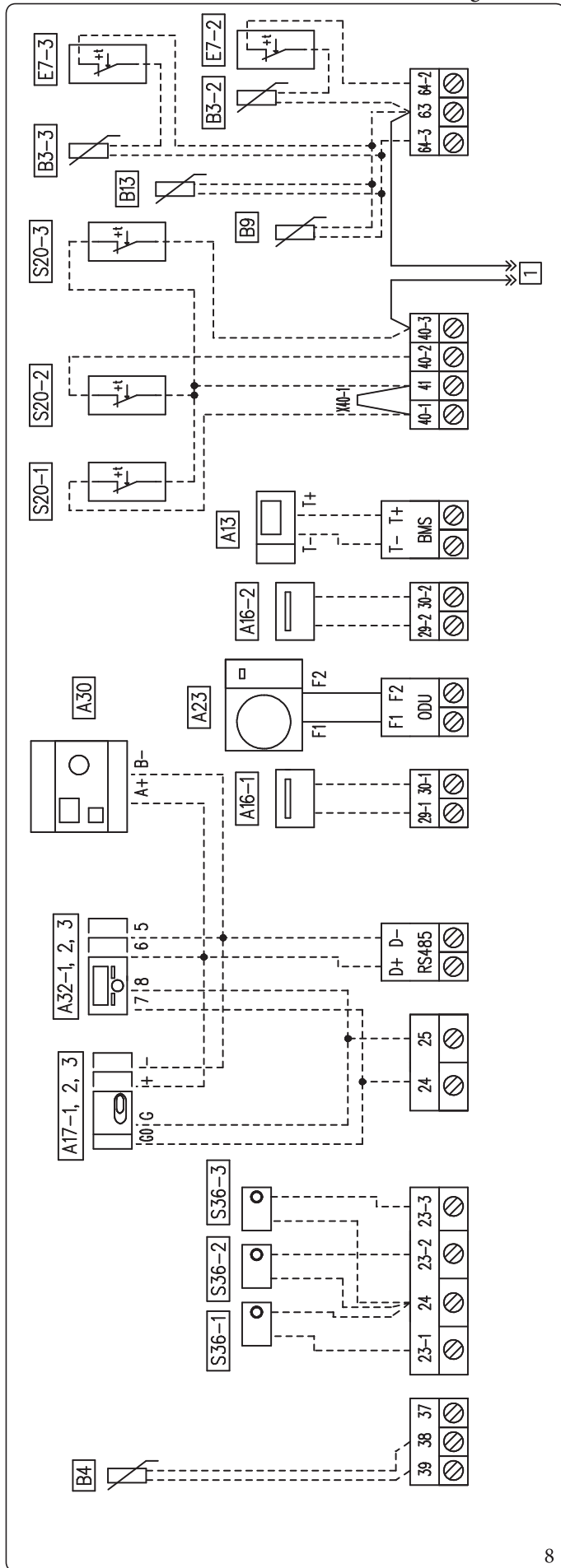

∞

Key (Fig. 8):

- A13 - System manager (optional)
- A16-1 - Zone 1 dehumidifier (optional with dehum. management board)
- A16-2 - Zone 2 dehumidifier (optional with dehum. management board)
- A17-1 - Zone 1 humidity sensor (optional)
- A17-2 - Zone 2 humidity sensor (optional)
- A17-3 - Zone 3 humidity sensor (optional)
- A23 - Outdoor unit
- A30 - Dominus
- A32-1 - Zone 1 remote panel (optional)
- A32-2 - Zone 2 remote panel (optional)
- A32-3 - Zone 3 remote panel (optional)
- B3-1 - Zone 1 flow probe (optional)
- B3-2 - Zone 2 flow probe (optional)
- B3-3 - Zone 3 flow probe (optional)
- B4 - External probe (optional)
- B9 - DHW inlet probe (optional)
- B13 - Central heating probe (optional)
- E7-2 - Zone 2 safety thermostat (low temperature) (optional)
- E7-3 - Zone 3 safety thermostat (low temperature) (optional)
- S20-1 - Zone 1 room thermostat (optional)
- S20-2 - Zone 2 room thermostat (optional)
- S20-3 - Zone 3 room thermostat (optional)
- S36-1 - Zone 1 humidistat (optional)
- S36-2 - Zone 2 humidistat (optional)
- S36-3 - Zone 3 humidistat (optional)
- X40-1 - Zone 1 room thermostat jumper
- 1 - Service connector

A16-1 and A16-2 dehumidifiers can be connected only after installing 2-relay board (optional).
 Remove jumper X40-1 before the electrical connection of the room thermostat zone 1.
 The TA inputs, 40-1 etc., must be electrically decoupled; e.g. a single command cannot pilot multiple inputs.

1.10 ROOM CHRONO-THERMOSTATS (OPTIONAL)

The indoor unit is prepared for the application of room chrono-thermostats or remote controls, which are available as optional kits. A maximum of 3 temperature controllers can be applied directly to the appliance. All Immergas chrono-thermostats are connected with 2 wires only. Carefully read the user and assembly instructions contained in the accessory kit.



Disconnect power to the unit before making any electrical connections.

On/Off Immergas digital chrono-thermostat.

The chrono-thermostat allows:

- set two room temperature value: one for day (comfort temperature) and one for night (reduced temperature);
- set a weekly programme with four daily switch on and switch off times;
- selecting the required function mode from the various possible alternatives:
 - manual mode (with adjustable temperature);
 - automatic mode (with set programme);
 - forced automatic operation (momentarily changing the temperature of the automatic program).

The chrono-thermostat is powered by two 1.5V LR6 type alkaline batteries.

On/Off chrono-thermostat electrical connection (Optional).



The operations described below must be performed after having removed the voltage from the appliance.

On/Off ambient thermostat or chrono-thermostat: must be connected to the 40-1 / 41 terminals, eliminating the X40-1 jumper for zone 1 and 40-2 / 41 for zone 2 and 40-3 / 42 for zone 3.

Make sure that the On/Off thermostat contact is of the “clean” type, i.e. independent of the mains voltage, otherwise the P.C.B. would be damaged.

The connections must be made on the terminal board inside the appliance’s control panel (Fig. 8).

1.11 MODBUS TEMPERATURE AND HUMIDITY ROOM PROBES (OPTIONAL)

The temperature and humidity probe is used to detect room humidity and to calculate the relative dew point by regulating the flow temperature during the cooling phase.

Connect the appliance as shown (Fig. 8).

DIP-Switch configuration table

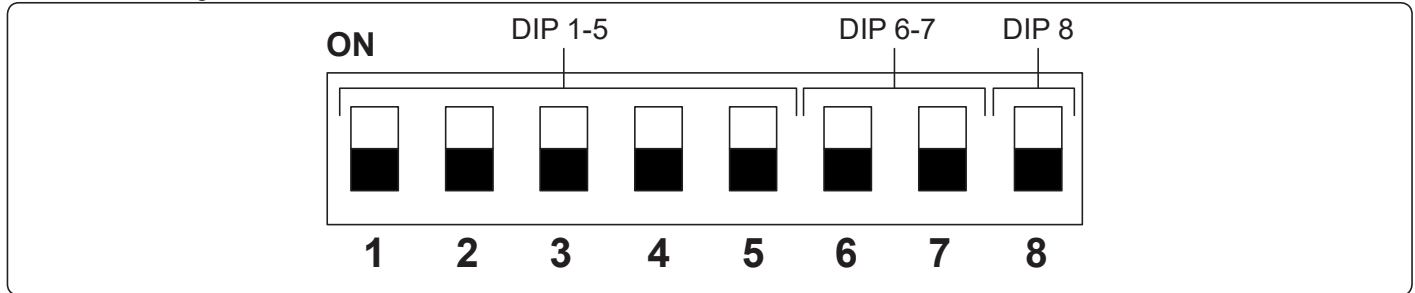

DIP 1-5 (Address)	<p>ON</p> <p>1 2 3 4 5</p>	Zone 1 (Address 131)
	<p>ON</p> <p>1 2 3 4 5</p>	Zone 2 (Address 132)
	<p>ON</p> <p>1 2 3 4 5</p>	Zone 3 (Address 133)

DIP 6-7 (Type)	<p>ON</p> <p>6 7</p>	Modbus 1 - 8 - E - 1
-------------------	----------------------	----------------------

DIP 8 (Speed)	<p>ON</p> <p>8</p>	9600 bit/s
------------------	--------------------	------------

INSTALLER

USER

MAINTENANCE TECHNICIAN

TECHNICAL DATA

1.12 REMOTE ZONE CONTROL (OPTIONAL)

This remote device is used to adjust the setpoints and to view the main information of the zone where it was configured.

Connect as shown (Fig. 8);

To correctly configure the device, set the parameters as described below:

Assistance Menu -> Device configuration	
Slave address: Address to configure according to the zone where the device is installed	Zone 1 = 41
	Zone 2 = 42
	Zone 3 = 43
Baud Rate	9600
Parity bit	Even
Stop bits	1
Heat pump control	NO



For correct operation it is necessary to install the jumper on the thermostat of the zone associated to the panel.
If necessary, this jumper can be replaced with a safety thermostat.

1.13 DOMINUS (OPTIONAL)

The system can be remote controlled using the optional Dominus kit.

Connect the appliance as shown (Fig. 8).

The following is necessary to enable Dominus:

- position the Dip Switches: OFF-OFF-OFF-ON;
- set the A30 parameter on the control panel = ON;
- configure the Dominus APP profile on Magis Pro-Combo V2.



The Dominus firmware must be updated at least to revision 2.02. Check that the P.C.B. firmware is at least revision 4.0

For further information, consult the relative instruction sheet.

1.14 HUMIDISTAT ON/OFF (OPTIONAL)

You can make a dehumidification demand by using a humidistat.

Connect as shown (Fig. 8)

1.15 EXTERNAL TEMPERATURE PROBE (OPTIONAL)

The outdoor unit has a standard external probe that can be used as an external probe of the heat pump.

This can be used as an external probe of the heat pump.

If the outdoor unit is positioned in an area that is not suitable for temperature reading, it is advisable to use an additional external probe (Fig. 9) which is available as an optional kit.

Refer to the relative instruction sheet for positioning of the external probe.

For the proper operation of the optional probe it must be connected where envisaged (Fig. 8) and then it must be enabled (Parag. 3.12).



Once the probe is enabled, switch the appliance off and back on.



The presence of the external probe allows the system flow temperature to be set automatically based on the outdoor temperature in order to adapt the heating or cooling provided to the system.

The system flow temperature is determined by the setting on the “Heat regulation” menu and by the “User” menu for the offset values based on the curves shown in the diagram (Parag. 1.16).



If the system is divided into two or three zones, the flow temperature is calculated based on the zone with the higher temperature in central heating mode and with the lower temperature in cooling mode.

The electric connection of the external probe must be made on terminals 38 and 39 on the terminal board on the indoor unit control panel (Fig. 8).

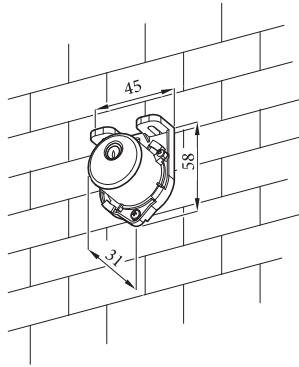

9

In case of failure, after having powered off and back on, the outdoor temperature is automatically detected by the external probe on the outdoor unit.

INSTALLER

USER

MAINTENANCE TECHNICIAN

TECHNICAL DATA

1.16 TEMPERATURE CONTROL SETTING

By setting the parameters in the “Heat regulation” menu, you can adjust how the system operates.

The curves (Fig. 10, 13, 11, 14, 12, 15) show the default settings in the various operating modes available both with external probe and without.

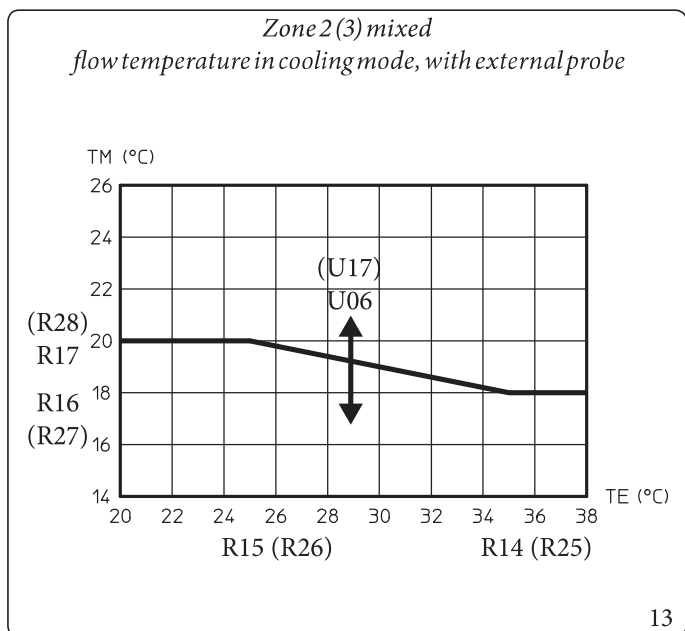
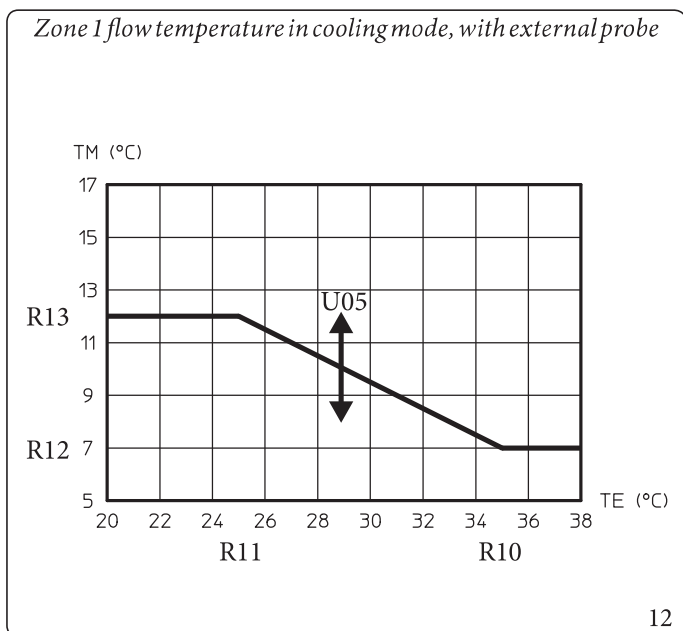
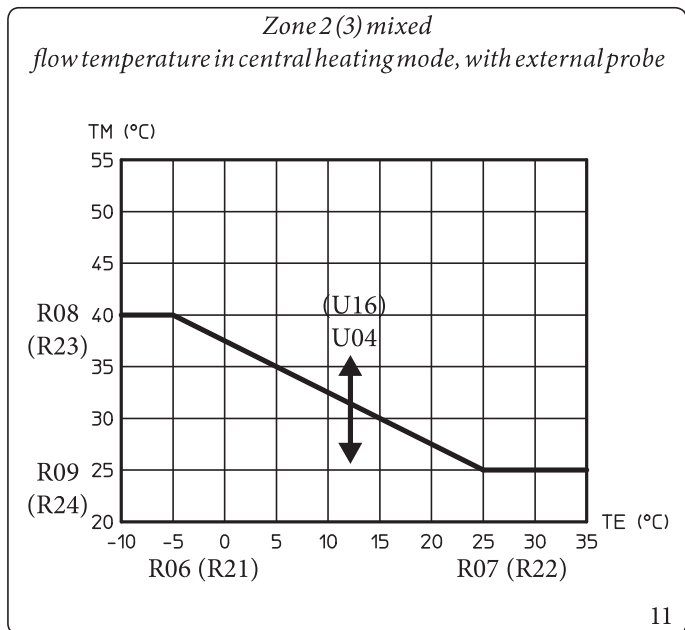
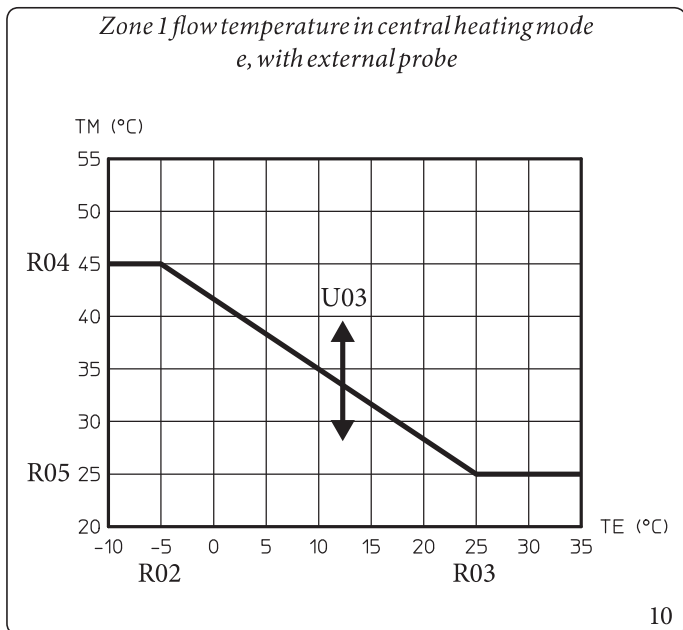

Key (Fig. 10, 13, 11, 14, 12, 15)

Rxx - Temperature control menu parameter

TE - Outside temperature

TM - Flow temperature

U03 - Offset value compared to the curve set by the external probe on central heating zone 1

U04 - Offset value compared to the curve set by the external probe on central heating zone 2

U05 - Offset value compared to the curve set by the external probe on cooling zone 1

U06 - Offset value compared to the curve set by the external probe on cooling zone 2

U16 - Offset value compared to the curve set by the external probe on central heating zone 3

U17 - Offset value compared to the curve set by the external probe on cooling zone 3

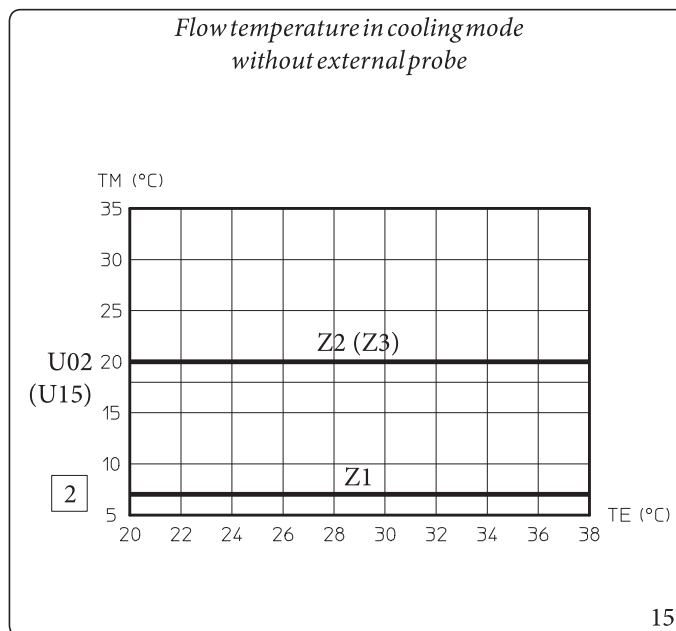
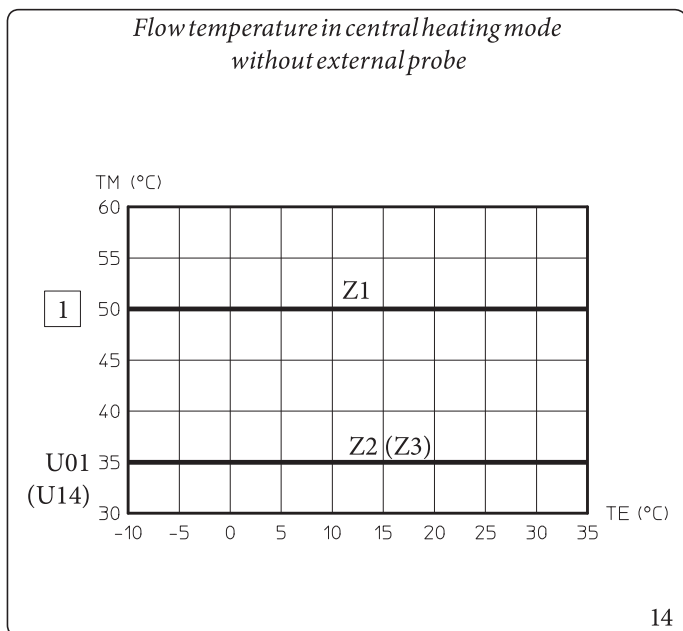

Key (Fig. 10, 13, 11, 14, 12, 15)

- 1 - Central heating set
- 2 - Cooling set
- TE - Outside temperature
- TM - Flow temperature
- U01 - Zone 2 flow temperature in "User" menu central heating mode
- U02 - Zone 2 flow temperature in "User" menu cooling mode

- U14 - Zone 3 flow temperature in "User" menu central heating mode
- U15 - Zone 3 flow temperature in "User" menu cooling mode
- Zx - Heating system zone

1.17 IMMERGAS FLUE SYSTEMS

Immergas supplies various solutions separately from the indoor units regarding the installation of air intake terminals and flue exhaust, which are fundamental for indoor unit operation.

 The indoor unit must be installed with an original Immergas "Green Range" inspectionable air intake system and flue gas extraction system made of plastic, with the exception of configuration C₆, as required by the regulations in force and by the product's approval. This flue can be identified by an identification mark and special distinctive marking bearing the note "only for condensation boilers".

For non-original flue system, refer to the technical data of the appliance.

 The plastic pipes cannot be installed outdoors, for tracts longer than 40 cm, without suitable protection from UV rays and other atmospheric agents.

Resistance factors and equivalent lengths

Each flue component has a Resistance Factor based on experimental tests and specified in the table below.

The Resistance Factor for individual components is independent from the type of boiler on which it is installed and has a dimensionless size.

It is however, conditioned by the temperature of the fluids that pass through the pipe and therefore, varies according to applications for air intake or flue exhaust.

Each single component has a resistance corresponding to a certain length in metres of pipe of the same diameter; the so-called equivalent length, can be obtained from the ratio between the relative Resistance Factors.

Example: Bend 90° Ø80 Intake Resistance Factor = 5.3; Pipe Ø80 m1 Intake Resistance Factor = 2.4; equivalent length Bend 90° Ø80 = 5.3 : 2.4 = 2.2 m of Pipe Ø80 in intake.

Similarly, each single component has a resistance corresponding to a certain length in metres of pipe of a different diameter; for example: concentric Bend 90° Ø60/100 Resistance Factor = 23; Pipe Ø80 m1 in exhaust, Resistance Factor = 3.4; Equivalent length Bend 90° Ø60/100 = 23 : 3.4 = 6.8 m of Pipe Ø80 in exhaust.

All indoor units have an experimentally obtainable maximum Resistance Factor equal to 100.

The maximum Resistance Factor allowed corresponds to the resistance encountered with the maximum allowed pipe length for each type of Terminal Kit.

This information allows calculations to be made to verify the possibility of setting up various flue configurations.

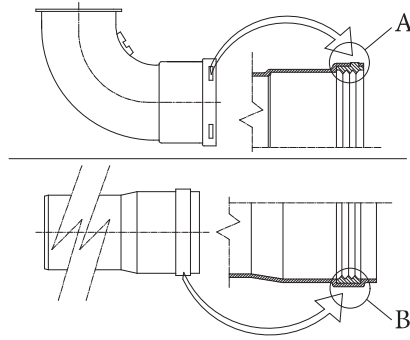

Positioning the gaskets (black) for “green range” flue systems.

Position the gasket correctly (for bends and extensions) (Fig. 16):

- gasket (A) with notches, to use for bends;
- gasket (B) without notches, to use for extensions.

If necessary, to ease the push-fitting, spread the elements with commonly-used talc.

Extension pipes and concentric elbows push-fittings.

To install push-fitting extensions with other elements of the flue, proceed as follows:

- Install the concentric pipe or elbow with the male side (smooth) on the female side (with lip seal) to the end stop on the previously installed element in order to ensure sealing efficiency of the coupling.



If the exhaust terminal and/or extension concentric pipe needs shortening, consider that the internal duct must always protrude by 5 mm with respect to the external duct.



For safety purposes, do not obstruct the indoor unit’s intake/exhaust terminal, not even temporarily
The various parts of the flue system must be checked to ensure that they have been laid in such a way as to prevent the coupled parts from detaching, in particular, the flue exhaust duct in the Ø80 separator kit configuration. If the condition described above is not adequately guaranteed, it will be necessary to use the appropriate retaining clamp kit.







When installing horizontal pipes, a minimum inclination of 1.5% towards the indoor unit must be maintained, and a section clamp with plug must be installed every 3 metres.

Installation inside the recessed frame

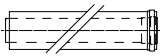
In this mode, install the flue according to your needs using the appropriate pre-sections in the frame to exit from its clearances.

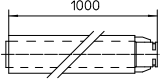
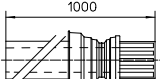
1.18 TABLES OF RESISTANCE FACTORS AND EQUIVALENT LENGTHS OF “GREEN RANGE” FLUE SYSTEM COMPONENTS











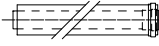

TYPE OF DUCT		Resistance factor (R)	Equivalent length in m of concentric pipe Ø 80/125
Concentric pipe 80/125 Ø m 1		2,1	1
90° concentric bend 80/125 Ø		3,0	1,4
Concentric bend 45° Ø 80/125		2,1	1
Terminal complete with concentric horizontal intake-exhaust Ø 80/125		2,8	1,3
Terminal complete with concentric vertical intake-exhaust Ø 80/125		3,6	1,7
90° concentric bend Ø 80/125 with inspection		3,4	1,6
Stub pipe with inspection Ø 80/125		3,4	1,6

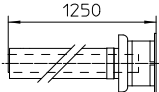
INSTALLER

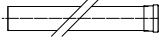
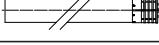
USER

MAINTENANCE TECHNICIAN

TECHNICAL DATA

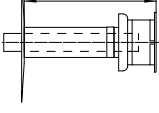
TYPE OF DUCT		Resistance factor (R)	Equivalent length in m of concentric pipe Ø 60/100	Equivalent length in m of pipe Ø 80	Equivalent length in m of pipe Ø 60	Equivalent length in m of concentric pipe Ø 80/125
Concentric pipe Ø 60/100 m 1		Intake m 6.4	m 1	Intake m 7.3	Exhaust m 1.9	m 3,0
		Exhaust m 6.4		Exhaust m 5.3		
90° concentric bend Ø 60/100		Intake m 8.2	m 1,3	Intake m 9.4	Exhaust m 2.5	m 3,9
		Exhaust m 8.2		Exhaust m 6.8		
45° concentric bend Ø 60/100		Intake m 6.4	m 1	Intake m 7.3	Exhaust m 1.9	m 3,0
		Exhaust m 6.4		Exhaust m 5.3		
Terminal complete with concentric horizontal intake-exhaust Ø 60/100		Intake m 15	m 2,3	Intake m 17.2	Exhaust m 4.5	m 7,1
		Exhaust m 15		Exhaust m 12.5		
Concentric horizontal intake-exhaust terminal Ø 60/100		Intake m 10	m 1,5	Intake m 11.5	Exhaust m 3.0	m 4,7
		Exhaust m 10		Exhaust m 8.3		
Terminal complete with concentric vertical intake-exhaust Ø 60/100		Intake m 16.3	m 2,5	Intake m 18.7	Exhaust m 4.9	m 7,7
		Exhaust m 16.3		Exhaust m 13.6		
Concentric vertical intake-exhaust terminal Ø 60/100		Intake m 9	m 1,4	Intake m 10.3	Exhaust m 2.7	m 4,3
		Exhaust m 9		Exhaust m 7.5		
Pipe Ø 80 m 1		Intake m 0.87	m 0,1	Intake m 1.0	Exhaust m 0.4	m 0,4
		Exhaust m 1.2	m 0,2	Exhaust m 1.0		m 0,5
Complete intake terminal Ø 80 m 1		Intake m 3	m 0,5	Intake m 3.4	Exhaust m 0.9	m 1,4
Intake terminal Ø 80 Exhaust terminal Ø 80		Intake m 2.2	m 0,35	Intake m 2.5	Exhaust m 0.6	m 1
		Exhaust m 1.9	m 0,3	Exhaust m 1.6		m 0,9
90° bend Ø 80		Intake m 1.9	m 0,3	Intake m 2.2	Exhaust m 0.8	m 0,9
		Exhaust m 2.6	m 0,4	Exhaust m 2.1		m 1,2
45° bend Ø 80		Intake m 1.2	m 0,2	Intake m 1.4	Exhaust m 0.5	m 0,5
		Exhaust m 1.6	m 0,25	Exhaust m 1.3		m 0,7
Pipe Ø 60 m 1 for ducting		Exhaust m 3.3	m 0,5	Intake m 3.8	Exhaust m 1.0	m 1,5
				Exhaust m 2.7		
90° bend Ø 60 for ducting		Exhaust m 3.5	m 0,55	Intake m 4.0	Exhaust m 1.1	m 1,6
				Exhaust m 2.9		
Reduction Ø 80/60		Intake m 2.6	m 0,4	Intake m 3	Exhaust m 0.8	m 1,2
		Exhaust m 2.6		Exhaust m 2.1		
Terminal complete with vertical exhaust Ø 60 for piping		Exhaust m 12.2	m 1,9	Intake m 14	Exhaust m 3.7	m 5,8
				Exhaust m 10.1		

1.19 OUTDOOR INSTALLATION IN PARTIALLY PROTECTED AREA



A partially protected area is one in which the appliance is not exposed to the direct action of the weather (rain, snow, hail, etc.).



This type of installation is possible when permitted by the laws in force in the appliance's country of destination.



If the appliance is installed in a place where the ambient temperature drops below -5°C , use the optional antifreeze kit, checking the ambient operating temperature range shown in the technical data table in this instruction booklet.

Configuration type B, open chamber and fan assisted (B_{23} or B_{53}).

Using the relevant cover kit, direct air intake is possible and flue gas is exhausted into a single flue or directly to the outside. In this configuration it is possible to install the indoor unit in a partially protected place. In this configuration the indoor unit is classified as type B.

With this configuration:

- air intake takes place directly from the environment in which the appliance is installed (external);
- the flue gas exhaust must be connected to its own single chimney (B_{23}) or ducted directly outside via a vertical terminal for direct exhaust (B_{53}) or via an Immergas ducting system (B_{53}).

The technical regulations in force must be respected.

Cover kit assembly (Fig. 18).

Remove the two plugs from the two lateral holes.

Install the $\varnothing 80$ outlet flange on the central hole of the boiler, taking care to insert the gasket supplied with the kit and tighten by means of the screws provided.

Install the upper cover, fixing it using the 4 screws present in the kit, positioning the relevant gaskets.

Engage the $90^{\circ} \varnothing 80$ bend with the male end (smooth) in the female end (with lip seal) of the $\varnothing 80$ flange unit to the end stop. Introduce the gasket, making it run along the bend. Fix it using the metal sheet plate and tighten by means of the clips present in the kit, making sure to block the 4 gasket flaps.

Fit the male end (smooth) of the exhaust pipe into the female end of the $90^{\circ} \varnothing 80$ bend, making sure that the relevant wall sealing plate is already fitted; this will ensure hold and joining of the elements making up the kit.

Max. length of exhaust duct.

The flue pipe (both vertical or horizontal) can be extended to a max. length of 30 linear metres.

Coupling of extension pipes.

To install push-fitting extensions with other elements of the flue, proceed as follows: Couple the pipe or elbow with the male side (smooth) in the female side (with lip seal) to the end stop on the previously installed element. This will ensure sealing efficiency of the coupling.

Configuration without cover kit in a partially protected location (type C boiler).

By leaving the side plugs fitted it is possible to install the appliance externally without the cover kit.

Installation takes place using the $\varnothing 60/100$ and $\varnothing 80/125$ concentric intake/ exhaust kits. Refer to the paragraph on indoor installation.

In this configuration the upper cover kit guarantees additional protection for the boiler. It is recommended but not compulsory.

The $\varnothing 80/80$ separating device cannot be used in this configuration (coupled with the cover kit).

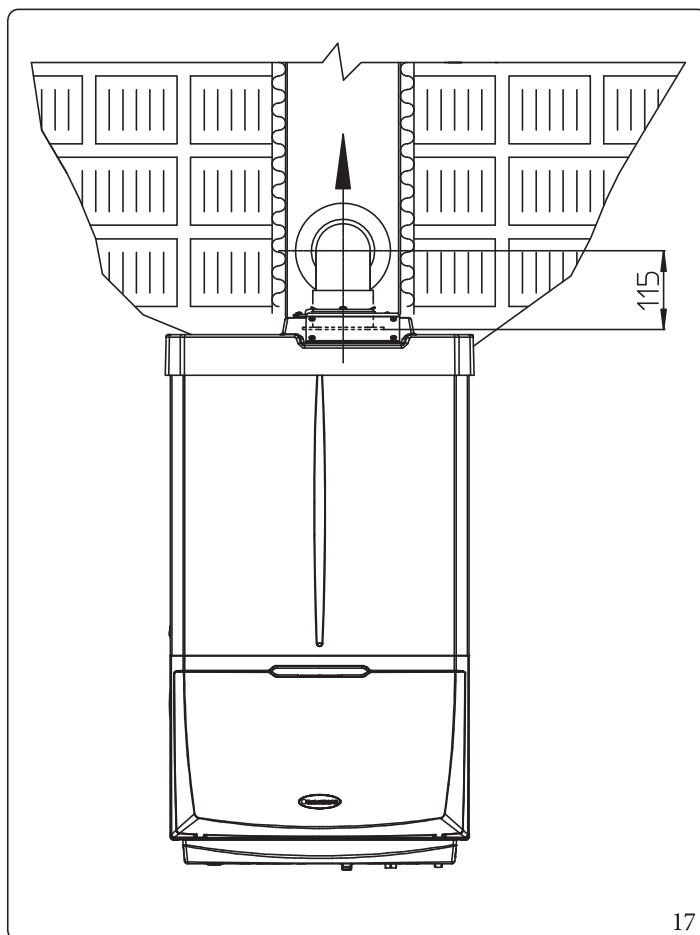

17

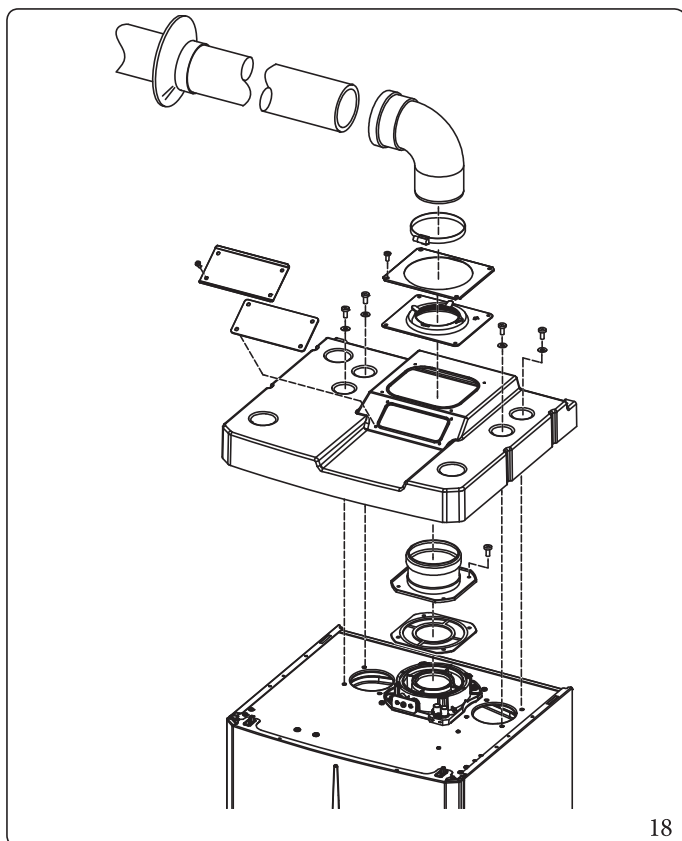

18

The terminal kit includes (Fig. 18):

- N°1 Gasket
- N°1 Exhaust flange Ø80
- N°1 Ø80 90° bend
- N°1 Exhaust pipe Ø80
- N°1 Wall sealing plate

The cover kit includes (Fig. 18):

- N°1 Thermoformed cover
- N°1 Gasket clamping plate
- N°1 Gasket
- N°1 Gasket tightening clip
- N°1 Intake hole covering plate

1.20 CONCENTRIC HORIZONTAL KIT INSTALLATION

Type C configuration, sealed chamber and fan assisted

The position of the terminal (in terms of distances from openings, overlooking buildings, floor, etc.) must be in compliance with the regulations in force.

This terminal is connected directly to the outside of the building for air intake and flue gas exhaust.

The horizontal kit can be installed with the rear, right side, left side or front outlet.

For installation with frontal outlet, one must use the fixing plate and a concentric bend coupling in order to ensure sufficient space to carry out the tests required by law upon commissioning.

External grid

Both the \varnothing 60/100 and \varnothing 80/125 intake/exhaust terminal, if properly installed, is pleasant to look at on the outside of the building. Make sure that the external silicone wall sealing plate is properly inserted in the wall.



For correct functioning of the system the terminal with grid must be installed correctly ensuring that, the "high" indication present on the terminal is respected on installation.

Mounting the horizontal intake-exhaust kit \varnothing 60/100 (Fig. 19)

1. Install the curve with flange (2) on the central hole of the indoor unit, positioning gasket (1) with the circular projections downwards in contact with the indoor unit flange, and tighten using the screws contained in the kit.
2. Fit the \varnothing 60/100 (3) concentric terminal pipe with the male side (smooth) to the female side of the bend (2) up to the end stop, making sure that the internal and external wall sealing plates have been fitted; this will ensure sealing and joining of the elements making up the kit.

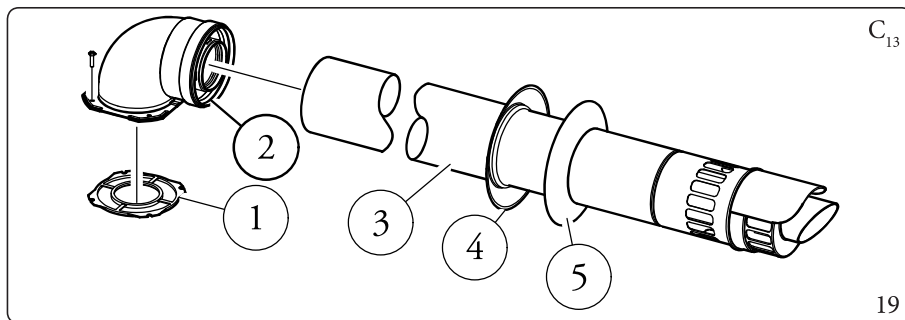

The kit includes (Fig. 19):

- N°1 Gasket (1)
- N°1 Concentric bend \varnothing 60/100 (2)
- N°1 Int./exhaust concentric terminal \varnothing 60/100 (3)
- N°1 Internal wall sealing plate (4)
- N°1 External wall sealing plate (5)

Extensions for \varnothing 60/100 horizontal kit. Kit assembly (Fig. 20)

This configuration corresponds to a resistance factor of 100.

The kit with this configuration can be extended up to a max. horizontal length of 12.9 m including the terminal with grid and excluding the concentric bend leaving the indoor unit; this configuration offers a resistance factor of 100. In this case specific extensions must be requested.

In this case the special extensions must be requested.

Immergas also provides a \varnothing 60/100 simplified terminal, which in combination with its extension kits allows you to reach a maximum extension of 11.9 metres.

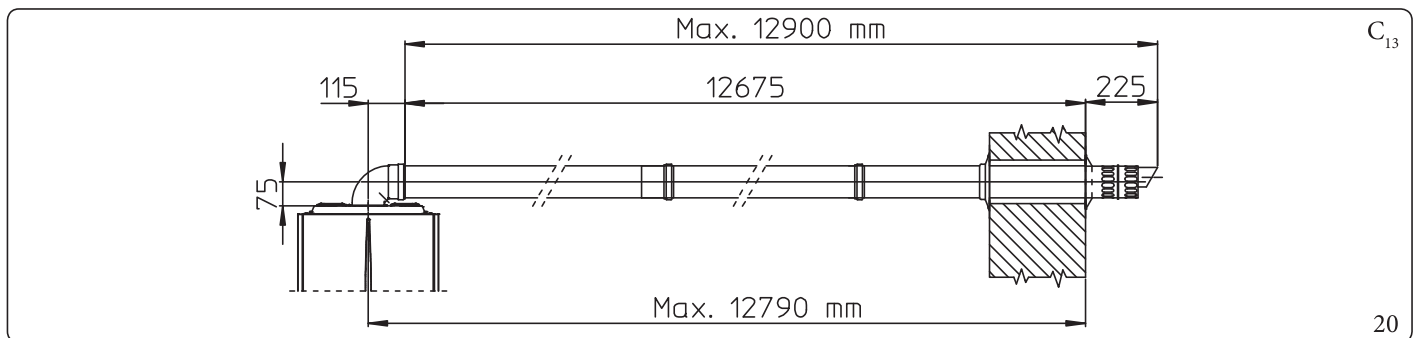

Mounting the horizontal intake-exhaust kit Ø 80/125 (Fig. 21)

To install the kit Ø 80/125 one must use the flanged adapter kit in order to install the flue system Ø 80/125.

1. Install the flanged adaptor (2) on the central hole of the indoor unit, positioning gasket (1) with the circular projections downwards in contact with the indoor unit flange, and tighten using the screws contained in the kit.
2. Engage the bend (3) with the male side (smooth) to the end stop on the adaptor (1).
3. Fit the Ø 80/125 (5) concentric terminal pipe with the male side (smooth) to the female side of the bend (4) (with lip seals) up to the end stop, making sure that the internal (6) and external wall sealing plates (7) have been fitted; this will ensure sealing and joining of the elements making up the kit.

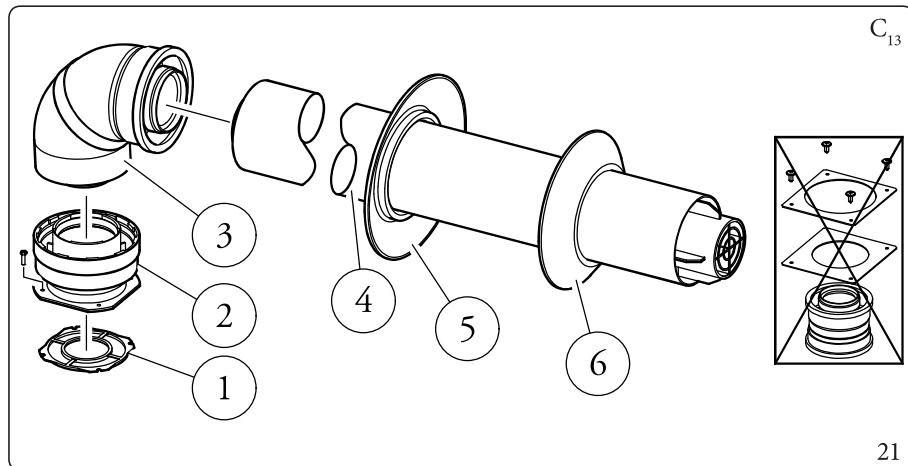

The adapter kit includes (Fig. 21):

- N°1 Gasket (1)
- N°1 Adapter Ø 80/125 (2)

The Kit Ø 80/125 includes (Fig. 21):

- N°1 Concentric bend Ø 80/125 at 87° (3)
 - N°1 Int./exhaust concentric terminal Ø 80/125 (4)
 - N°1 Internal wall sealing plate (5)
 - N°1 External wall sealing plate (6)
- The remaining kit components must not be used

Extensions for Ø 80/125 horizontal kit. Kit assembly (Fig. 22)

The kit with this configuration can be extended up to a max. length of 32 m, including the terminal with grid and excluding the concentric bend leaving the indoor unit.

If additional components are assembled, the length equivalent to the maximum allowed must be subtracted.

In this case the special extensions must be requested.

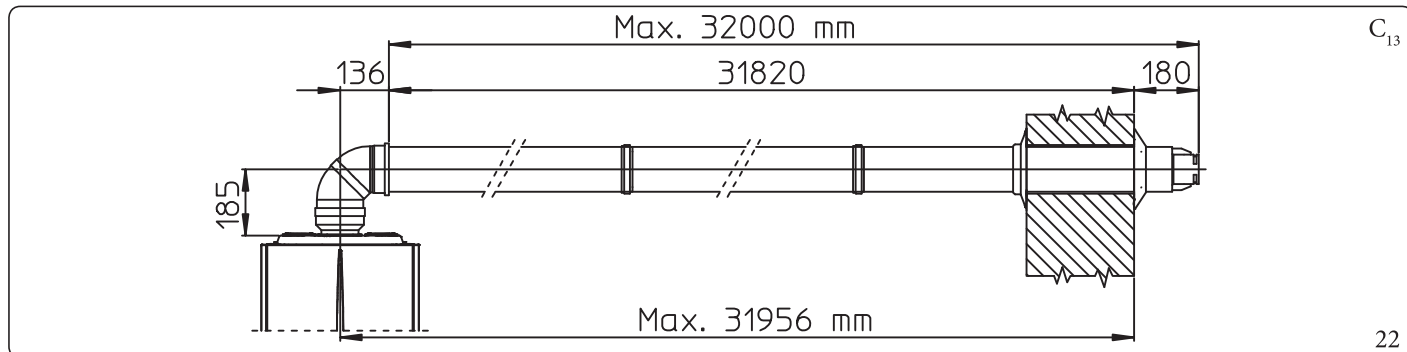

1.21 CONCENTRIC VERTICAL KIT INSTALLATION

Type C configuration, sealed chamber and fan assisted

Concentric vertical intake and exhaust kit.

This vertical terminal is connected directly to the outside of the building for air intake and flue gas exhaust.



The vertical kit with aluminium tile enables installation on terraces and roofs with a maximum slope of 45% (approx. 25°) and the height between the terminal cap and half-shell (374 mm for Ø 60/100 and 260 mm for Ø 80/125) must always be observed.

Mounting the vertical kit with aluminium tile Ø 60/100 (Fig. 23)

1. Install the concentric flange (2) on the central hole of the indoor unit, positioning gasket (1) with the circular projections downwards in contact with the indoor unit flange.
2. Tighten the concentric flange with the screws in the kit.
3. Replace the tiles with the aluminium sheet (4), shaping it to ensure that rainwater runs off.
4. Position the fixed half-shell (6) on the aluminium tile.
5. Insert the intake-exhaust pipe (5).
6. Fit the Ø 60/100 concentric terminal pipe with the male side (5) (smooth) into the flange (2) up to the end stop, making sure that the wall sealing plate has been fitted (3); this will ensure sealing and joining of the elements making up the kit.

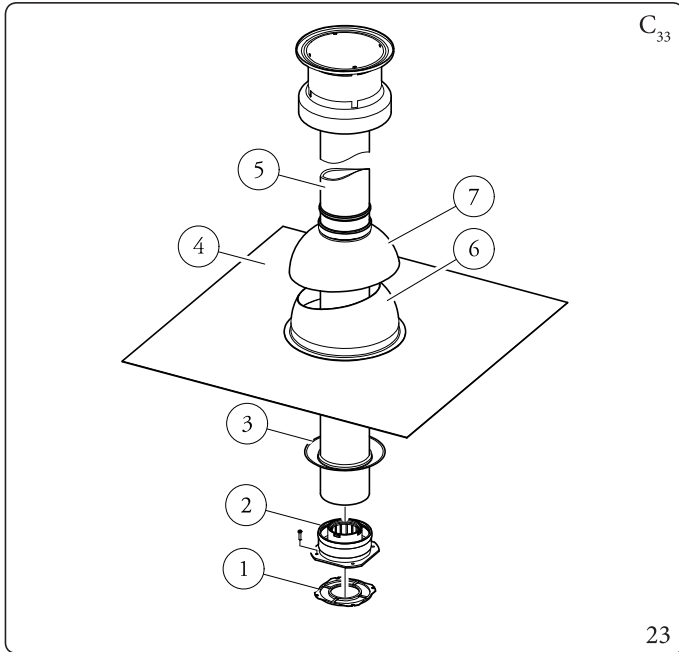

The kit includes (Fig. 23):

- N°1 Gasket (1)
- N°1 Female concentric flange (2)
- N°1 Wall sealing plate (3)
- N°1 Aluminium tile (4)
- N°1 Concentric intake/exhaust pipe Ø 60/100 (5)
- N°1 Fixed half-shell (6)
- N°1 Mobile half-shell (7)



When the indoor unit is installed in areas where very rigid temperatures can be reached, a special antifreeze kit is available that can be installed as an alternative to the standard kit.

Extensions for Ø 60/100 vertical kit (Fig. 24)

The kit with this configuration can be extended up to a max. vertical straight length of 14.4 m including the terminal. This configuration corresponds to a resistance factor of 100. In this case specific extensions must be requested.

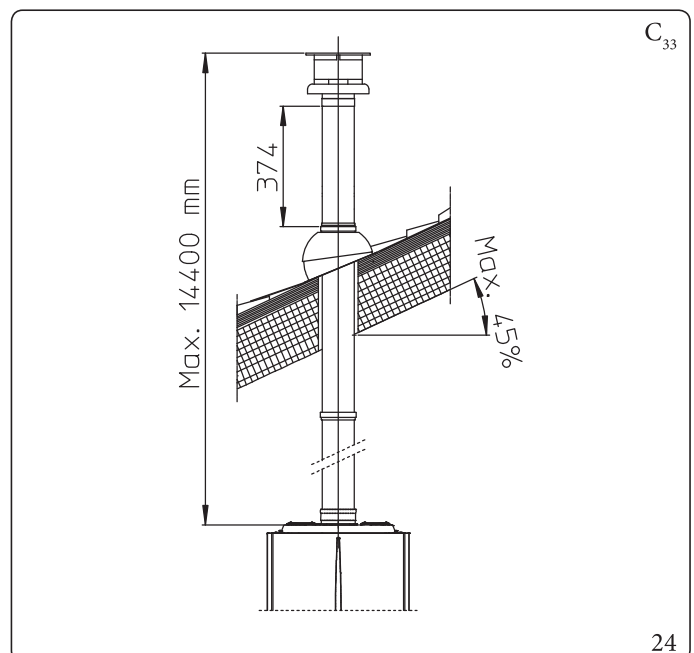

Mounting the vertical kit with aluminium tile Ø 80/125 (Fig. 25)



To install the kit Ø 80/125 one must use the flanged adapter kit in order to install the flue system Ø 80/125.

1. Install the concentric flange (2) on the central hole of the indoor unit, positioning gasket (1) with the circular projections downwards in contact with the indoor unit flange.
2. Tighten the concentric flange with the screws in the kit.
3. Replace the tiles with the aluminium sheet (4), shaping it to ensure that rainwater runs off.
4. Position the fixed half-shell (5) on the aluminium tile;
5. Insert the intake-exhaust terminal (7);
6. Fit the Ø 80/125 concentric terminal pipe with the male side (smooth) to the female side of the adapter (1) (with lip seals) up to the end stop, making sure that the wall sealing plate (3) has been fitted; this will ensure sealing and joining of the elements making up the kit.

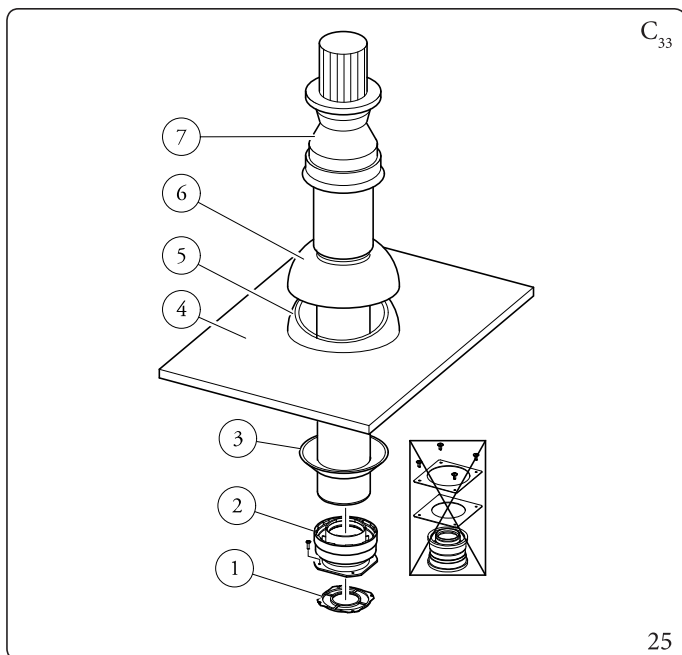

The adapter kit includes (Fig. 25):

- N°1 Gasket (1)
- N°1 Adapter Ø 80/125 (2)

The Kit Ø 80/125 includes (Fig. 25):

- N°1 Wall sealing plate (3)
- N°1 Aluminium tile (4)
- N°1 Fixed half-shell (5)
- N°1 Mobile half-shell (6)
- N°1 Concentric intake/exhaust pipe Ø 80/125 (7)

The remaining kit components must not be used

Extensions for Ø 80/125 vertical kit (Fig. 26)

The kit with this configuration can be extended to a max. straight vertical length of 32 m, including the terminal. If additional components are assembled, the length equivalent to the maximum allowed must be subtracted. In this case the special extensions must be requested.

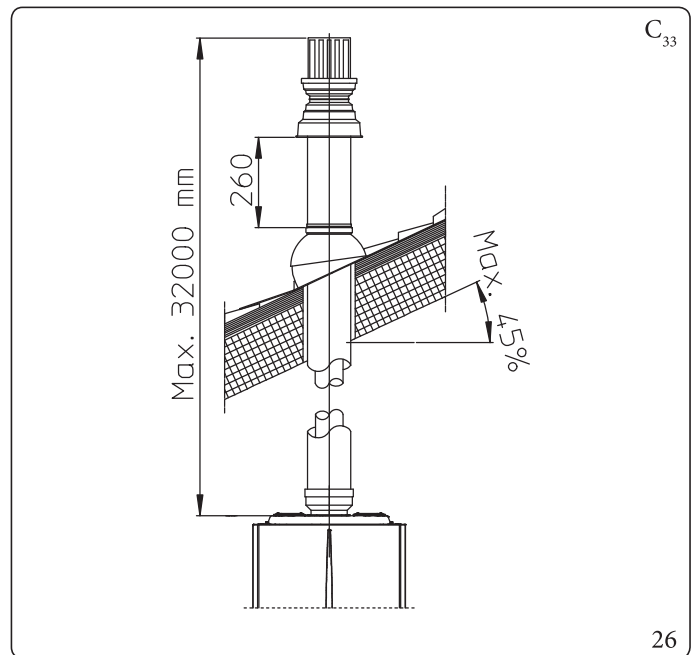

1.22 SEPARATOR KIT INSTALLATION

Type C configuration, sealed chamber and fan assisted, separator kit Ø 80/80

This kit allows air to come in from outside the building and the exhaust to exit from the chimney, flue or intubated duct through divided flue exhaust and air intake pipes.

Combustion products are expelled from pipe (S) (in plastic, so as to resist acid condensate).

Air is taken in through duct (A) for combustion (this is also in plastic).

The intake pipe (A) can be installed either on the right or left hand side of the central exhaust pipe (S).

Both ducts can be routed in any direction.

Mounting the separator kit Ø 80/80 (Fig. 27):

1. Install the flange (4) on the central hole of the indoor unit, positioning gasket (1) with the circular projections downwards in contact with the indoor unit flange.
2. Tighten with the hexagonal head and flat point screws provided in the kit.
3. Replace the flat flange present in the lateral hole with respect to the central one (according to needs) with the flange (3), positioning the gasket (2) already present in the indoor unit in between.
4. Tighten with the supplied self-tapping screws with drill bit.
5. Fit the bends with male side (smooth) (5) in the female side of the flanges (3 and 4).
6. Fit the intake terminal (6) with the male side (smooth) in the female side of the bend (5) up to the end stop, ensuring that the internal and external wall sealing plates are fitted
7. Fit the exhaust pipe (9) with the male end (smooth) to the female end of the bend (5) up to the end stop; making sure that the internal wall sealing plate has been fitted, this will ensure sealing and joining of the elements making up the kit.

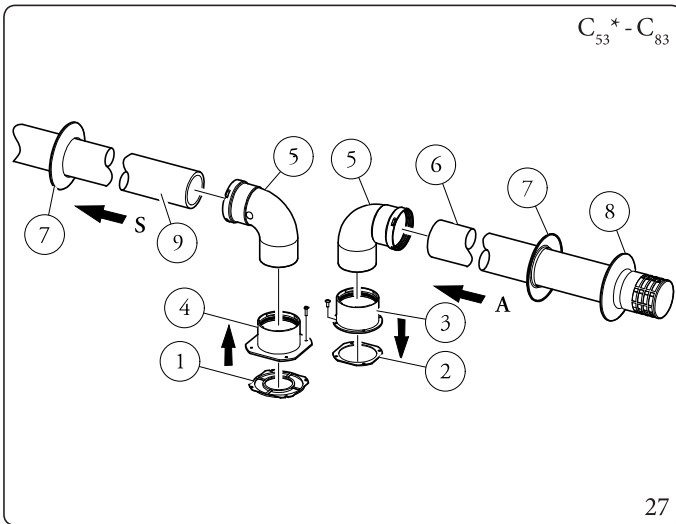

The kit includes (Fig. 27):

- N°1 Exhaust gasket (1)
- N°1 Flange gasket (2)
- N°1 Female intake flange (3)
- N°1 Female exhaust flange (4)
- N°2 Ø 80 90° bend (5)
- N°1 Intake terminal Ø 80 (6)
- N°2 Internal wall sealing plates (7)
- N°1 External wall sealing plate (8)
- N°1 Exhaust pipe Ø 80 (9)

* to complete C53 configuration, also provide for a "green range" roof discharge terminal. The configuration on walls opposite the building is not allowed.

Installation clearances (Fig. 28)

The minimum installation clearance measurements of the Ø 80/80 separator terminal kit have been stated in some limit conditions.

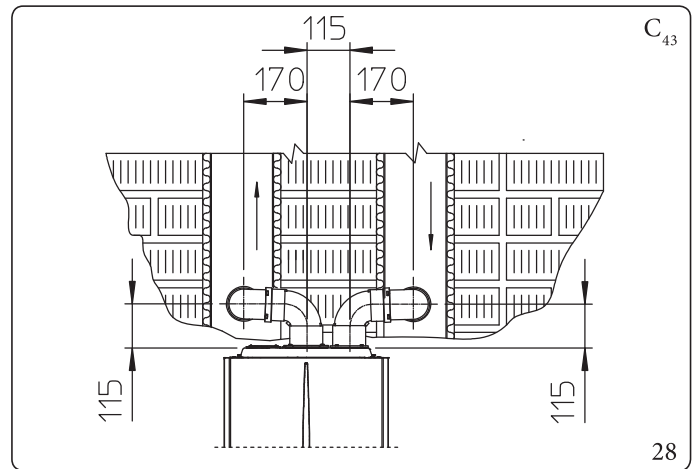

Extensions for separator kit Ø 80/80

The maximum vertical straight length (without bends) that can be used for Ø 80 intake and exhaust pipes is 41 metres, regardless from whether they are used for intake or exhaust.

The maximum horizontal straight length (with bend in suction and in exhaust) that can be used for Ø 80 intake and exhaust pipes is 36 metres, regardless from whether they are used for intake or exhaust.

Please note the type of installation C₄₃ must be done with a natural draught flue.



To favour the removal of possible condensate forming in the exhaust pipe, tilt the pipes towards the indoor unit with a minimum slope of 1.5% (Fig. 29)

1.23 C9 ADAPTOR KIT INSTALLATION

This kit allows an Immergas indoor unit to be installed in "C₉₃" configuration, with combustion air intake directly from the shaft where the flue gas exhaust is, obtained by means of a ducting system.

System composition

The system must be combined with the following components (sold separately) to be functional and complete:

- kit C₉₃ Ø 100 or Ø 125 version;
- rigid ducting Ø 60 and Ø 80 and flexible Ø 50 and Ø 80 kit;
- flue exhaust kit Ø 60/100 or Ø 80/125 configured according to the installation and type of indoor unit.

Mounting the C₉ adaptor kit (Fig. 31)

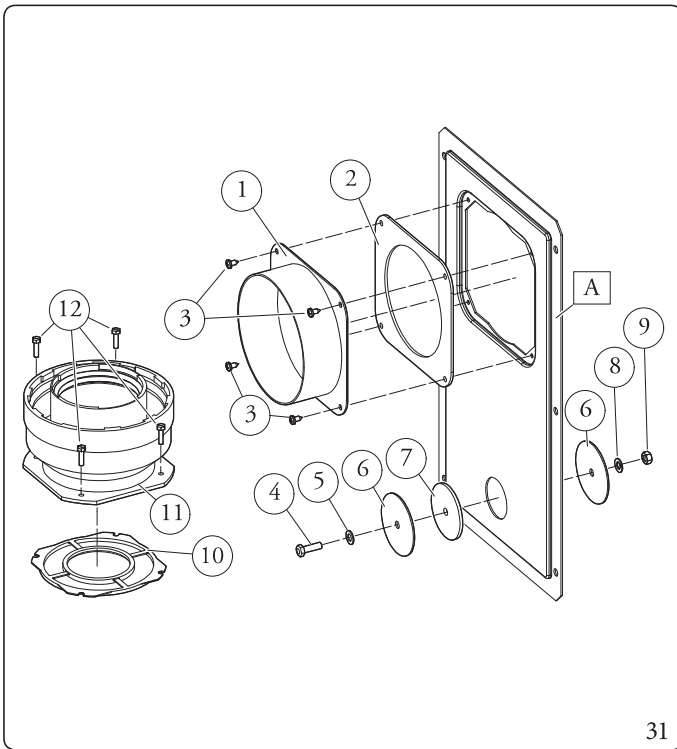

31

The adapter kit includes (Fig. 31):

- N°1 Door adaptor Ø 100 or Ø 125 (1)
- N°1 Door gasket made of neoprene (2)
- N°4 Screws 4.2x9 AF (3)
- N°1 Hex headed screw M6x20 (4)
- N°1 Flat nylon washer M6 (5)
- N°2 Door hole closure metal-sheet plate plug (6)
- N°1 Pluggasket made of neoprene (7)
- N°1 Toothed washer M6 (8)
- N°1 Nut M6 (9)
- N°1 (kit Ø 80/125) Concentric gasket Ø 60/100 (10)
- N°1 (kit Ø 80/125) Flanged adapter Ø 80/125 (11)
- N°4 (kit Ø 80/125) Hex headed screws M4 x 16 slotted screwdriver (12)
- N°1 (kit Ø 80/125) Bag of lubricating talc

Supplied separately (Fig. 31):

- N°1 Ducting kit door (A)

Technical data

The dimensions of the shafts must ensure a minimum gap between the outer wall of the smoke duct and the inner wall of the shaft: 30 mm for circular section shafts and 20 mm in the event of a square section shaft (Fig. 30).

Maximum 2 changes of direction are allowed on the vertical section of the flue system with a maximum clearance angle of 30° with respect to the vertical.

The maximum vertical extension using a Ø 60 ducting system is 22 m, the maximum extension includes 1 bend Ø 60/100 at 90°, 1 m of horizontal pipe Ø 60/100, 1 x 90° ducted bend Ø 60 and the roof terminal for ducting.

The maximum vertical extension using a Ø 80 rigid ducting system is 28 m, the maximum extension includes 1 adapter from Ø 60/100 to Ø 80/125, 1 bend Ø 80/125 of 87°, 1 m of pipe Ø 80/125 in horizontal, 1 x 90° ducted bend Ø 80 and the roof terminal for ducting.

To determine the C_{93} flue system in configurations other than that described (Fig. 32) one must consider the following head losses:

- 1 m of concentric pipe Ø 80/125 = 1.8 m of rigid ducted pipe Ø 80 and 0.7 m of flexible ducted pipe Ø 80;
- 1 curve Ø 80 of 87° = 2.1 m of rigid ducted pipe Ø 80 and 0.9 m of flexible ducted pipe Ø 80.

Consequently one must subtract the equivalent length of the part added to the 28 m available.

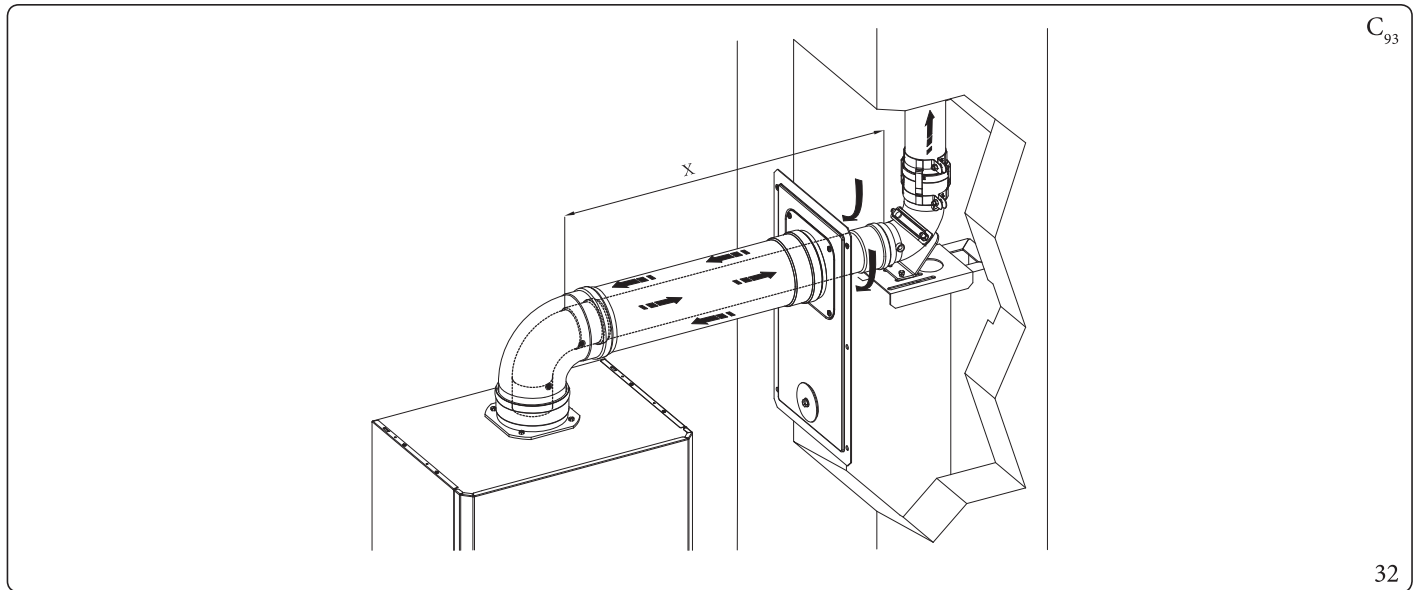

1.24 DUCTING OF FLUES OR TECHNICAL SLOTS

Ducting is an operation through which, via the introduction of one or more relevant pipes, one achieves a system for the evacuation of the combustion products of a gas appliance, made up from the coupling of an existing or new ducting pipe with a chimney, flue or technical slot (also in new buildings) (Fig. 33).

Ducting requires ducts declared to be suitable for the purpose by the manufacturer, following the installation and user instructions, provided by the manufacturer and the requirements of the regulations in force.

Immergas ducting systems



The Ø 60 rigid, Ø 50 and Ø 80 flexible and Ø 80 rigid “Green Range” ducting systems must only be used for domestic use and with Immergas condensing boilers.

In any case, ducting operations must respect the provisions contained in the standard and in current technical regulations; in particular, the declaration of conformity must be compiled at the end of work and on commissioning of the ducted system.

The instructions in the project or technical report must likewise be followed, in cases provided for by the standard and current technical regulations.

To guarantee reliability and operation over time of the ducting system, make sure:

- it is used in average atmospheric and environmental conditions, according to current regulations (absence of combustion products, dusts or gases that can alter the normal thermophysical or chemical conditions; existence of temperatures coming within the standard range of daily variation, etc.).
- Installation and maintenance must be performed according to the indications supplied by the manufacturer included with the “green range” ducting system chosen and in compliance with the regulations in force.
- The maximum length specified by the manufacturer must be respected; in this regard:
 - The max. possible length of the Ø 60 rigid ducting vertical section is equal to 22 m. This length is obtained considering the complete Ø 80 exhaust terminal, 1 m of Ø 80 pipe in exhaust, two 90° Ø 80 bends at indoor unit outlet.
 - The max. possible length of the Ø 80 flexible ducting vertical section is equal to 18 m. This length is obtained considering the Ø 80 complete exhaust terminal, 1 m of Ø 80 pipe in exhaust, two 90° Ø 80 bends at indoor unit outlet for connecting to the ducting system and two direction changes of the flexible hose inside the chimney/technical slot.
 - The max. possible length of the Ø 80 rigid ducting vertical section is equal to 30 m. This length is obtained considering the complete Ø 80 exhaust terminal, 1 m of Ø 80 pipe in exhaust, two 90° Ø 80 bends at indoor unit outlet.



You can also install an additional Ø 50 flexible ducting system the specifications of which are found on the relevant instructions sheet inside the kit.

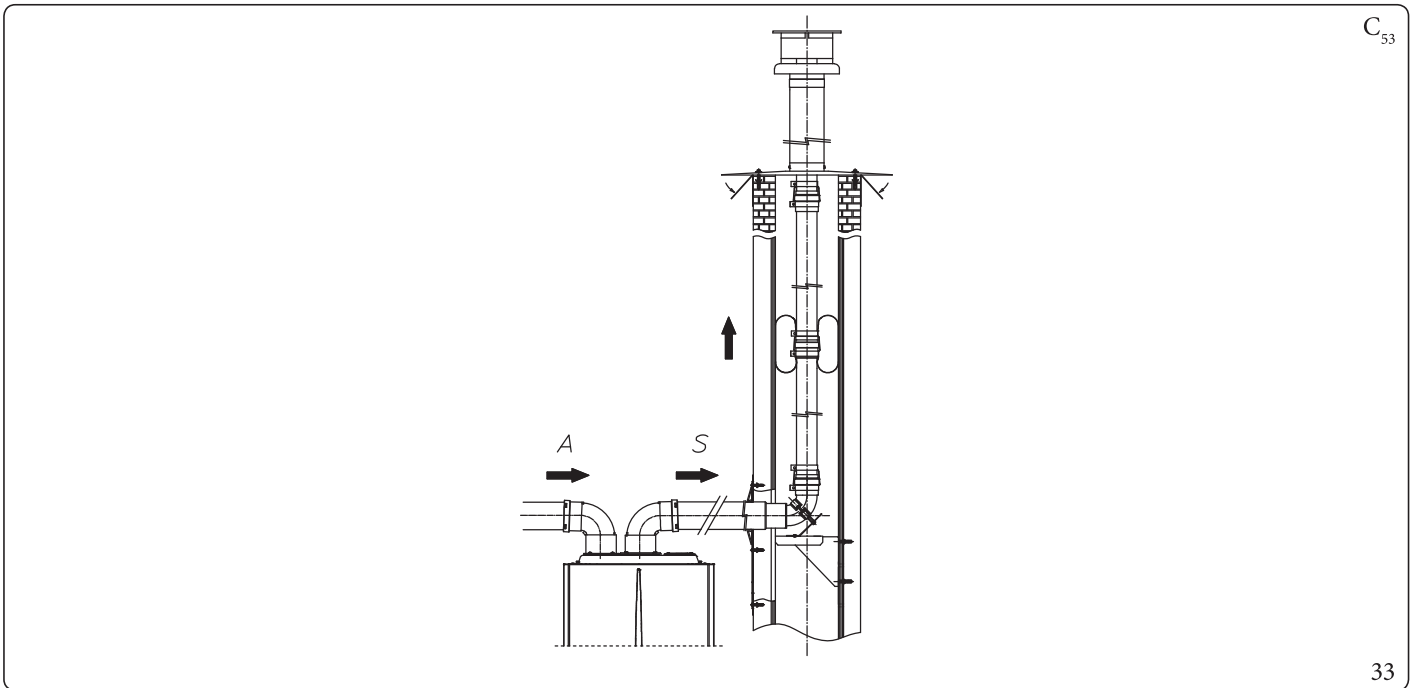

33

1.25 CONFIGURATION TYPE B, OPEN CHAMBER AND FAN ASSISTED FOR INDOORS

The appliance can be installed inside buildings in B₂₃ or B₅₃ mode; in this case, all technical rules and national and local regulations in force, must be complied with.

For installation, the cover kit must be used, referred to in (Par. 1.19).

1.26 FLUE EXHAUST TO FLUE/CHIMNEY.

Flue exhaust does not necessarily have to be connected to a branched type traditional flue for type B appliances with natural draught (CCR).

The flue exhaust, for indoor units installed in C configuration, can be connected to a special LAS type multiple flue.

For B₂₃ configurations, exhaust is only allowed into individual chimney or directly into the external atmosphere via a relevant terminal, unless otherwise provided by local regulations.

The multiple flues and the combined flues must also only be connected to type C appliances of the same type (condensation), having nominal heat inputs that do not differ by more than 30% less with respect to the maximum that can be attached and powered by the same fuel. The thermo-fluid dynamic features (flue flow rate, % of carbon dioxide, % humidity etc.) of the appliances attached to the same multiple flues or combined flues, must not differ by more than 10% with respect to the average indoor unit attached.

Multiple and combined flues must be specially designed according to the calculation method and requirements of the standards (such as UNI 13384), by professionally qualified technical staff.

Chimney or flue sections for connection of the flue exhaust pipe must comply with requisites of technical standards in force. It is possible to replace a type C conventional device with one provided with condensation only, if the derogation conditions established by the regulations in force have been verified.

1.27 FLUES, CHIMNEYS AND CHIMNEY CAPS.

The flues, chimneys and chimney caps for the evacuation of combustion products must be in compliance with applicable standards. The flues, chimneys and chimney caps for the evacuation of combustion products must be in compliance with applicable standards. Chimneys and roof-installed exhaust terminals must comply with the outlet height and with the distance from technical volumes set forth by the technical standards in force.

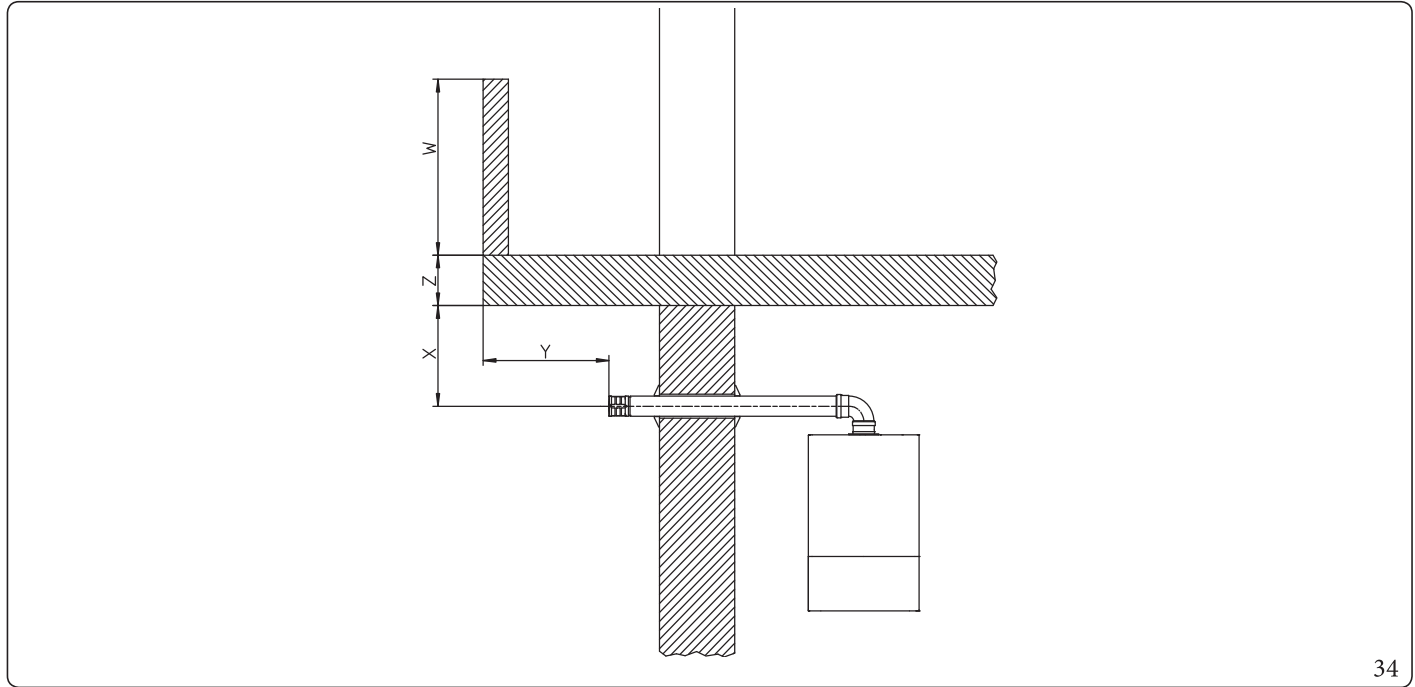

34

Positioning the wall flue exhaust terminals.

The wall flue exhaust terminals must:

- be installed on external perimeter walls of the building (Fig. 34);
- be positioned according to the minimum distances specified in current technical standards.

Combustion products exhaust of natural draught or fan assisted appliances in open-top closed environments.

In spaces closed on all sides with open tops (ventilation pits, courtyards etc.), direct combustion product exhaust is allowed for natural draught or fan assisted gas appliances with a heat input range from 4 to 35 kW, provided the conditions as per the current technical standards are respected.

1.28 WATER TREATMENT PLANT FILLING

As already mentioned in the previous paragraphs, a treatment of the thermal and domestic system water is required, in compliance with the local standards in force.

The parameters that influence the duration and proper operation of the heat exchanger are the water's PH, total hardness, conductivity, and oxygen, together with the system's processing residues (any welding residues), any oil present and corrosion products that can, in turn, cause damage to the heat exchanger.

In order to prevent this from happening, you are recommended to:

- clean the system with clean water to eliminate solid residues before installation on new and old systems;
- clean the system with a chemical treatment:
 - clean the new system with a suitable cleaning device (for example Sentinel X300, Fernox Cleaner F3 or Jenaqua 300) combined with thorough washing;
 - clean the old system with a suitable cleaning device (for example Sentinel X400 or X800, Fernox Cleaner F3 or Jenaqua 400) combined with thorough washing;
- Check the maximum total hardness and quantity of filling water referring to the graphics (Fig. 35); if the contents and hardness of the water are below the indicated curve, no specific treatment is required; otherwise, to limit the content of calcium carbonate, you must provide for water-filling treatment.
- If it is necessary to provide for water treatment, it should be done through complete desalination of the filling water. As opposed to the complete softening process, desalinating the water completely not only removes hardening agents (Ca, Mg), but also eliminates all other minerals to reduce water-filling conductivity up to 10 microsiemens/cm. Given its low conductivity, desalinated water does not only prevent the formation of lime scale, but also serves as protection against corrosion.
- Insert a suitable inhibitor / passivator (for example Sentinel X100, Fernox Protector F1, or Jenaqua 100); if required, also insert appropriate antifreeze (such as for example Sentinel X500, Fernox Alphi 11 or Jenaqua 500).
- Check electrical conduction of the water, which should be higher than 2000 $\mu\text{s}/\text{cm}$ in the case of treated water and lower than 600 $\mu\text{s}/\text{cm}$ in the case of non-treated water.
- To prevent corrosion, the water system's PH should be between 7.5 and 9.5.
- Check the maximum content of chlorides, which should be less than 250 mg/l.



For quantities and methods of use of water-treatment products, refer to the instructions provided by their manufacturer.

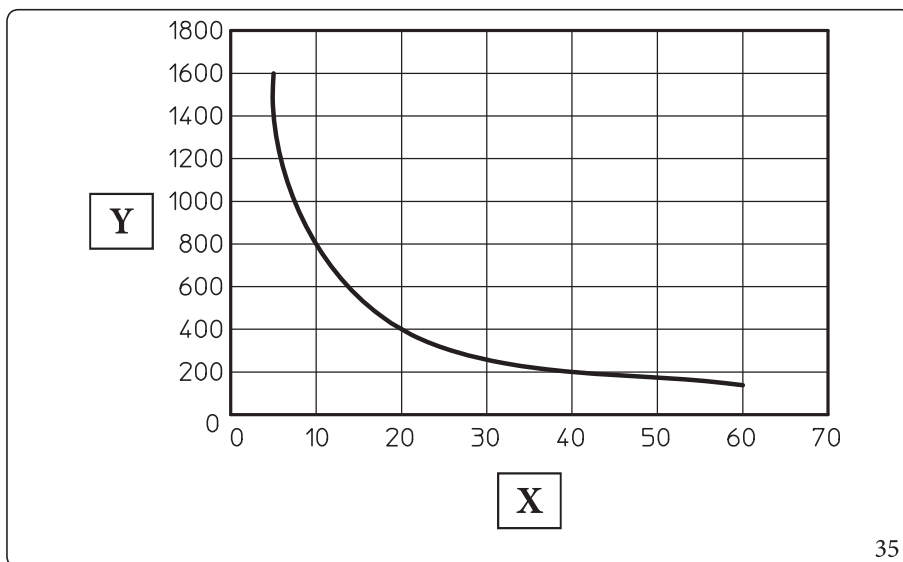

Key (Fig. 35):

- X - Total water hardness °F
- Y - Litres of system water



The graph refers to the entire life cycle of the system. Therefore, also consider scheduled and unscheduled maintenance, which involves emptying and filling the said system.

1.29 SYSTEM FILLING

Once the indoor unit is connected, fill the system using the filling cock (Fig. 41).

Filling must be done slowly to allow the air bubbles in the water to escape through the vents in the indoor unit and the heating and air conditioning system.

The indoor unit has one incorporated automatic vent valve located on the circulator and another on the central heating manifold.



Make sure that the hoods are loosened.

The filling cock must be closed when the indoor unit pressure gauge indicates approximately 1.2 bar.



During these operations, enable the “Venting” functions by setting the “U 50” parameter to ON, which lasts about 18 hours (Parag. 3.12).

System minimum water content.

Minimum water content favours the **proper execution of defrosting cycles** and operation in cooling mode. To this end, the minimum amount of water to guarantee is **30 litres** for any type of system and in any operating mode.

1.30 FILLING THE CONDENSATE DRAIN TRAP



When the indoor unit is switched on for the first time, combustion products come out of the condensate drain. After a few minutes of operation, check that combustion flue gases are no longer coming out of the condensate drain; this means that the drain trap has filled to a correct condensate height that the flue gases cannot pass through.

1.31 GASSYSTEMSTART-UP.

To start up the system, refer to the technical standards in force.

This divides the systems and, therefore, the commissioning operations, into three categories: new systems, modified systems, reactivated systems.

In particular, for new gas systems:

- open windows and doors;
- avoid presence of sparks or naked flames;
- bleed all air from pipelines;
- ensure the internal system is properly sealed according to the specifications set forth by technical regulations in force.

1.32 OPERATING LIMITS

The appliance was designed to work in a specific range of outdoor temperatures and at a specific maximum flow temperature. (Fig. 36, 37) shows these limits.

These limit values apply to heating or cooling operation.

Domestic hot water supply is always met in any outdoor temperature conditions.

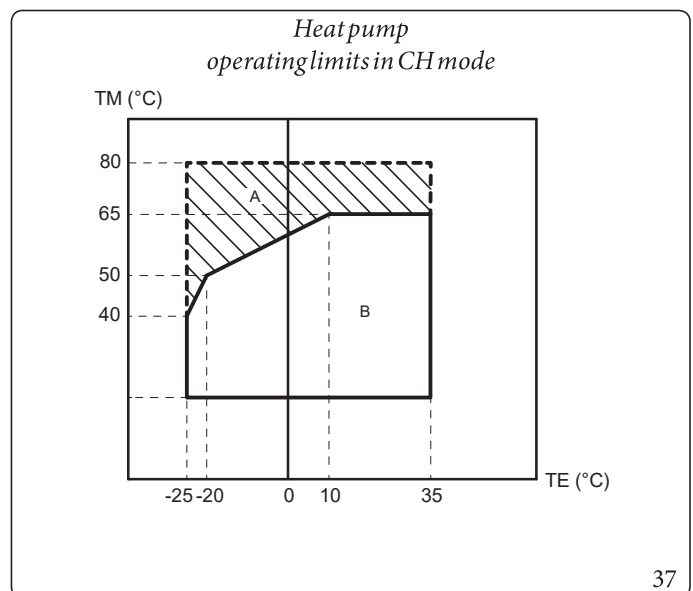
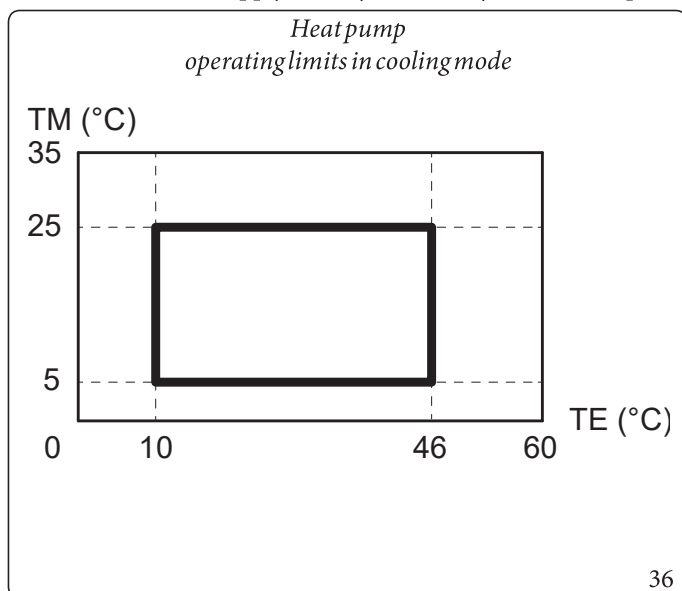

Key (Fig. 36, 37, 38):

TE = Outside temperature

TM = Flow temperature

A = Only with heat generator

B = In heat pump (with heat generator, if necessary)

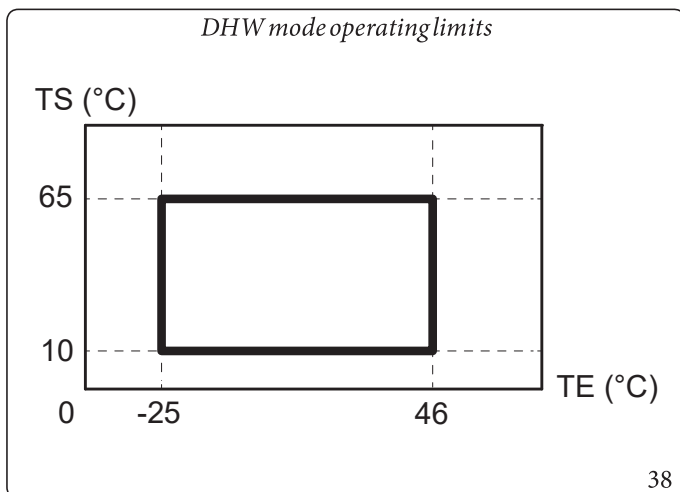

Key (Fig. 36,37,38):

TE = Outside temperature

TS = DHW outlet temperature

A = Only with heat generator

B = In heat pump (with heat generator, if necessary)

1.33 COMMISSIONING THE INDOOR UNIT (IGNITION, ONLY WHEN PAIRED WITH AN OUTDOOR UNIT)

To commission the indoor unit (the operations listed below must only be performed by qualified personnel and in the presence of staff only):

1. check that the internal system is properly sealed according to the specifications set forth by regulations in force;
2. Make sure that the type of gas used corresponds to indoor unit settings;
3. check that there are no external factors that may cause the formation of fuel pockets;
4. Check that the gas flow rate and the relative pressure values comply with those indicated in the booklet;
5. Switch the indoor unit on and check correct ignition;
6. ensure that the safety device intervenes in the event of gas supply failure and check the relative intervention time;
7. check connection to a 230V-50Hz power mains, correct L-N polarity and the earthing connection;
8. Check the intervention of the main switch located upstream from the indoor unit and in the indoor unit.
9. check that the intake/exhaust terminals are not obstructed and that they are installed properly;



The system must not be started up if even only one of the checks should be negative.



After installation, check for leaks. Toxic gas could be generated if the unit comes into contact with a source of ignition, such as thermal fan, stove and cylinders. Make sure that only refrigerant recovery cylinders are used.

1.34 CIRCULATION PUMP

The indoor unit is supplied with two circulator pumps, one for the heat generator and another for the heat pump mode.

Circulator pumps run at variable speeds and operate as follows:

- **Fixed ("A 05" = 0):** The heat circulator pump speed is fixed and corresponds to parameter "A 04". The heat generator circulator pump speed is fixed and corresponds to parameter "A 19".
- **ΔT constant ("A 05" = 5 K):** the heat circulator pump speed varies to maintain $\Delta T = 5$ K constant between the system flow and return. Also, you can adjust the pump operating range, by setting the maximum speed "A 04" and the minimum speed "A 03". The heat generator circulator pump speed varies to maintain $\Delta T = "A 05"$ constant between the system flow and return. Also, you can adjust the pump operating range, by setting the maximum speed "A 19" and the minimum speed "A 18".



For proper system operation, make sure that the minimum flow rate in operating conditions never drops below 500l/h.

Pump LED.

The LED flashes green when the pump is powered and the pwm control signal is connected.



The LED lights up steady green when the pump is powered and the signal cable disconnected. In these conditions the pump works at maximum and without control.

If the pump detects an alarm, the LED switches from green to red; this can mean one of the following failures:

- low supply voltage;
- rotor seized;
- electrical error.

For a detailed description of the meaning of the red LED, refer to (Parag. 3.7).



The LED, in addition to being green or red, can also remain off.

It is normal for the LED to be off when the pump is not powered, whereas with the pump powered, the LED must be lit: if switched off, it means there is a fault.

Pump release.

If after a long period of inactivity, the circulator is blocked, adjust the screw in the centre of the head in order to manually release the motor shaft.

Take great care during this operation to avoid damage to the motor.

Head available to system (Heat generator circuit)

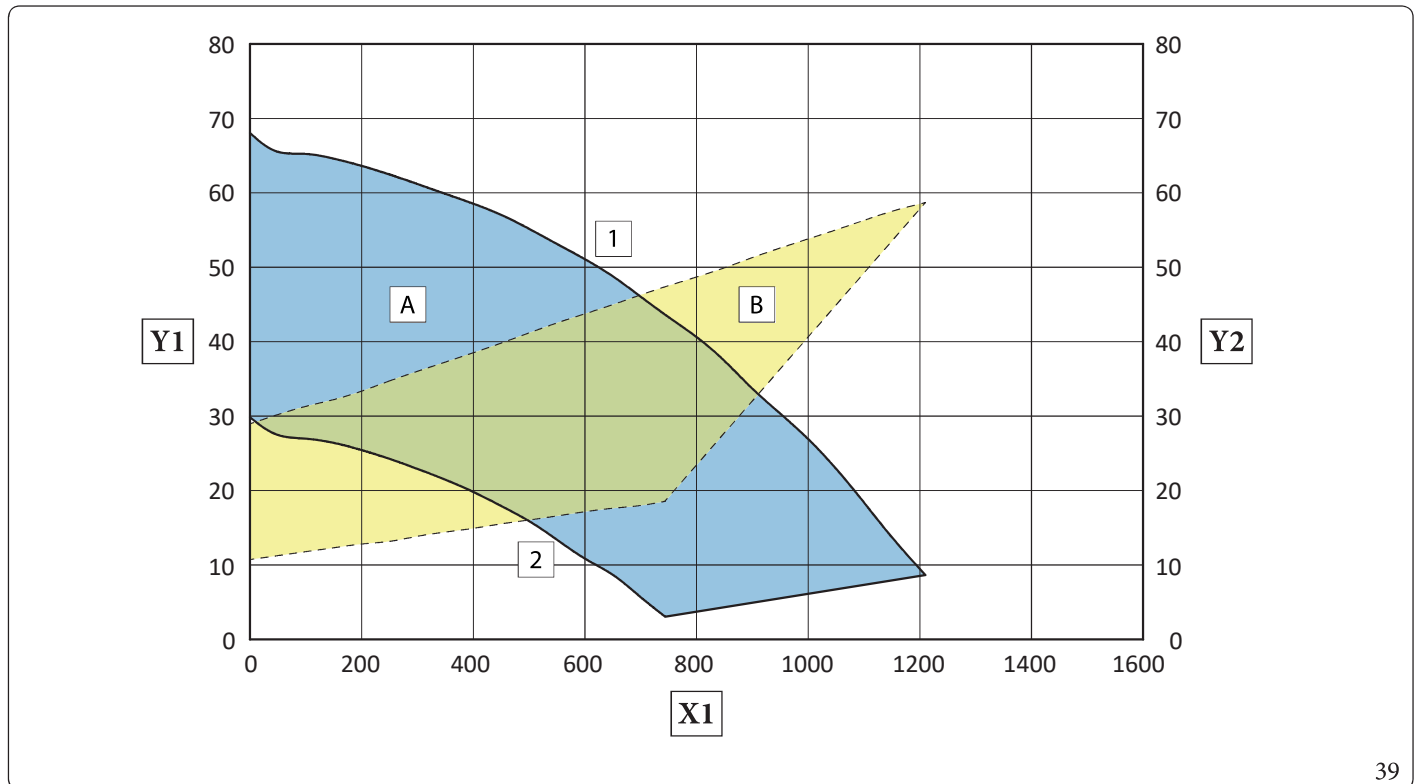

Key (Fig. 39):

- X1 = Flowrate (l/h)
- Y1 = Head (kPa)
- Y2 = Circulator pump absorbed power (W)
- 1 = Maximum speed (100%)
- 2 = Minimum speed (70%)
- A = Head available to the system
- B = Absorbed power by the circulator (dotted area)

Head available to system (Heat pump circuit)

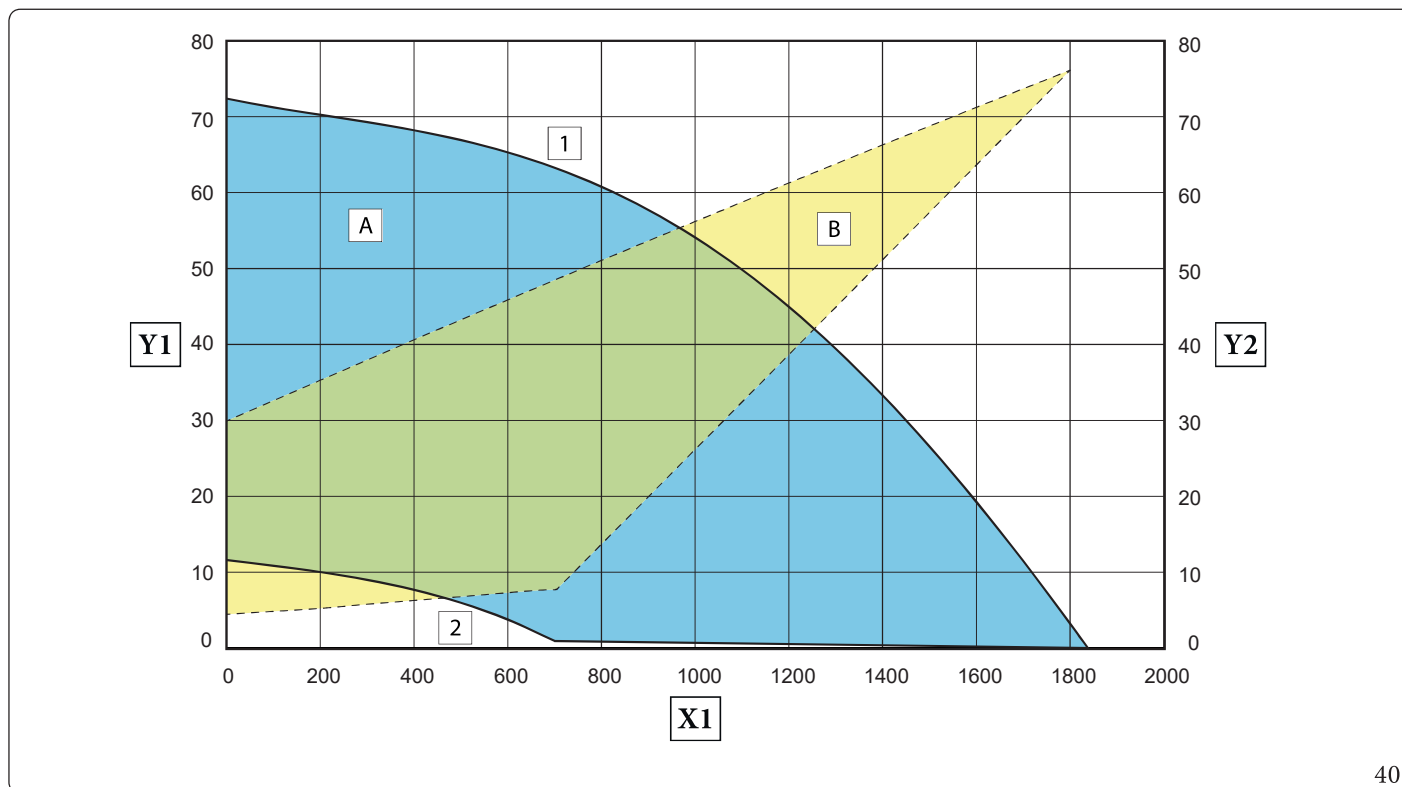

40

Key (Fig. 40):

- X1 = Flow rate (l/h)
- Y1 = Head (kPa)
- Y2 = Circulator pump absorbed power (W)
- 1 = Maximum speed (100%)
- 2 = Minimum speed (45%)
- A = Head available to the system
- B = Absorbed power by the circulator (dotted area)

1.35 KITS AVAILABLE ON REQUEST

- 2 zone kit (1 direct and 1 mixed). Should it be necessary, you can install the zone kit, which allows you to divide the heating system into two separate zones - one direct and one mixed.
- Configurable relay interface kit. The module is set up for a relay board, which amplifies the appliance features and, thus, the operating possibilities.
- 2-relay board kit. The indoor unit can manage up to two dehumidifiers. A 2 relay board that manages dehumidifier enabling is available to pair the appliances.
- R32 circuit connection kit. For R32 circuit wall connections, there is a kit with the two pipes necessary to create the circuit.



The above-mentioned kits are supplied complete with instructions for assembly and use.

1.36 MAIN COMPONENTS

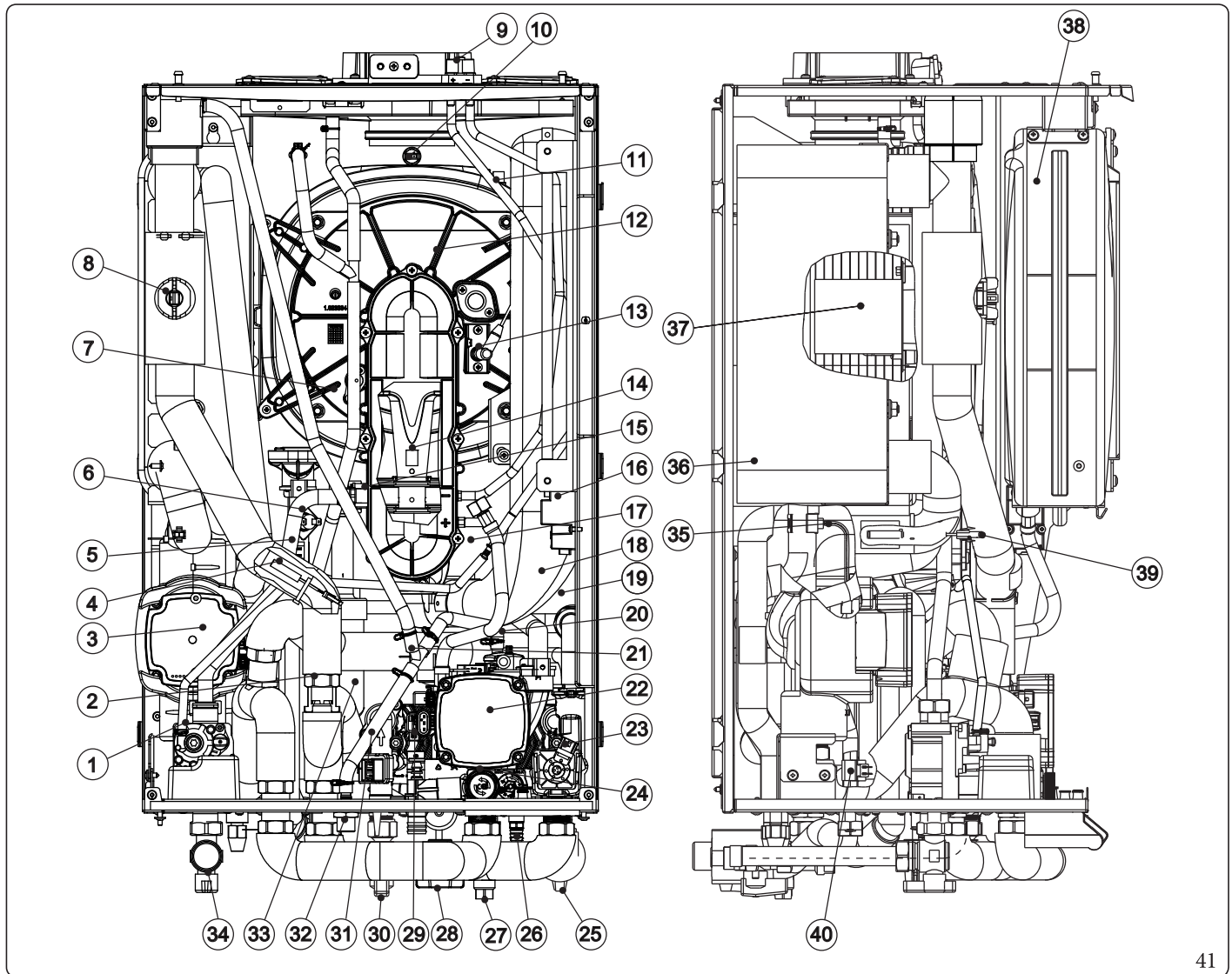

Key (Fig. 41):

- | | | | |
|----|------------------------------------|----|-------------------------------------|
| 1 | - Gas valve | 20 | - Air vent valve |
| 2 | - One-way valve | 21 | - System pressure switch |
| 3 | - Heat pump circuit circulator | 22 | - Heat generator circuit circulator |
| 4 | - Heat pump flow probe | 23 | - Heat generator three-way valve |
| 5 | - Heat generator flow probe | 24 | - 3 bar safety valve |
| 6 | - Safety thermostat | 25 | - System shut-off cock |
| 7 | - Detection electrode | 26 | - System draining fitting |
| 8 | - System flow-meter | 27 | - System shut-off cock with filter |
| 9 | - Flange with sample points | 28 | - System filling cock |
| 10 | - Flue gas thermofuse | 29 | - Plate heat exchanger |
| 11 | - Heat exchanger safety thermofuse | 30 | - Domestic hot water inlet cock |
| 12 | - Condensation module | 31 | - D.H.W. flow switch |
| 13 | - Ignition glow plug | 32 | - Air vent valve |
| 14 | - Venturi | 33 | - Condensate drain trap |
| 15 | - Gas nozzle | 34 | - Gas interception cock |
| 16 | - Igniter | 35 | - Liquid phase detection probe |
| 17 | - Fan | 36 | - Water-gas plate exchanger |
| 18 | - Air intake pipe | 37 | - Burner |
| 19 | - One-way valve | 38 | - System expansion vessel |
| | | 39 | - Heat generator return probe |
| | | 40 | - D.H.W. probe |

INSTALLER

USER

MAINTENANCE TECHNICIAN

TECHNICAL DATA

41

2 INSTRUCTIONS FOR USE AND MAINTENANCE

2.1 GENERAL RECOMMENDATIONS



Never expose the indoor unit to direct vapours from a hob.



The device can be used by children at least 8 years old as well as by persons with reduced physical, sensory or mental capabilities, or lack of experience or required knowledge, provided that they are under surveillance, or after they have been instructed relating to the safe use and have understood the potential dangers.

Children must not play with the appliance.

Cleaning and maintenance destined to be performed by the user can not be carried out by unsupervised children.



For safety purposes, check that the air intake/flue exhaust terminals (if fitted) are not blocked.



If temporary shutdown of the indoor unit is required, proceed as follows:

- a) drain the heating system if antifreeze is not used;
- b) shut-off all electrical, water and gas supplies.



In the case of work or maintenance to structures located in the vicinity of ducting or devices for flue extraction and relative accessories, switch off the appliance and on completion of operations ensure that a qualified technician checks efficiency of the ducting or other devices.



Never clean the appliance or connected parts with easily flammable substances.



Never leave containers or flammable substances in the same environment as the appliance.



Do not open or tamper with the appliance.



Do not take apart or tamper with the intake and exhaust pipes.



Only use the user interface devices listed in this section of the booklet.



Do not climb on the appliance, do not use the appliance as a support base.



The use of components involving use of electrical power requires some fundamental rules to be observed such as:

- do not touch the appliance with wet or moist parts of the body; do not touch when barefoot;
- never pull electrical cables or leave the appliance exposed to atmospheric agents (rain, sunlight, etc.);
- the appliance power cable must not be replaced by the user;
- in the event of damage to the cable, switch off the appliance and contact exclusively qualified staff for replacement;
- if the appliance is not to be used for a certain period, disconnect the main indoor unit external switch.



Water at a temperature of more than 50 °C can cause serious burns. Always check the water temperature before any use.



The temperatures indicated by the display have a tolerance of +/- 3°C due to environmental conditions that cannot be blamed on the indoor unit.



After brief periods of inactivity, visually check that the siphon is properly filled with condensate and top it up if necessary.



If you smell gas in the building:

- close the gas meter interception device or the main interception device;
- if possible, close the gas interception cock on the product;
- if possible, open doors and windows wide and create an air current;
- do not use open flames (e.g. lighters, matches);
- do not smoke;
- do not use electrical switches, plugs, door bells, telephones or intercom devices in the building;
- call an authorised company (e.g. Authorised Technical Assistance Centre).



if you smell burning or see smoke coming out of the appliance, switch it off, disconnect power, close the main gas cock, open the windows and call an authorised company (e.g. Authorised Technical Assistance Centre).



At the end of its service life, the appliance must not be disposed of like normal household waste nor abandoned in the environment, but must be removed by a professionally authorised company as required by current legislation. Contact the manufacturer for disposal instructions.

2.2 CLEANING AND MAINTENANCE



To preserve the boiler's integrity and keep the safety features, performance and reliability, which distinguish it, unchanged over time, you must execute maintenance operations on a yearly basis in compliance with what is stated in the relative point at “annual check and maintenance of the appliance” in compliance with the prevailing national, regional or local provisions.

2.3 CONTROL PANEL

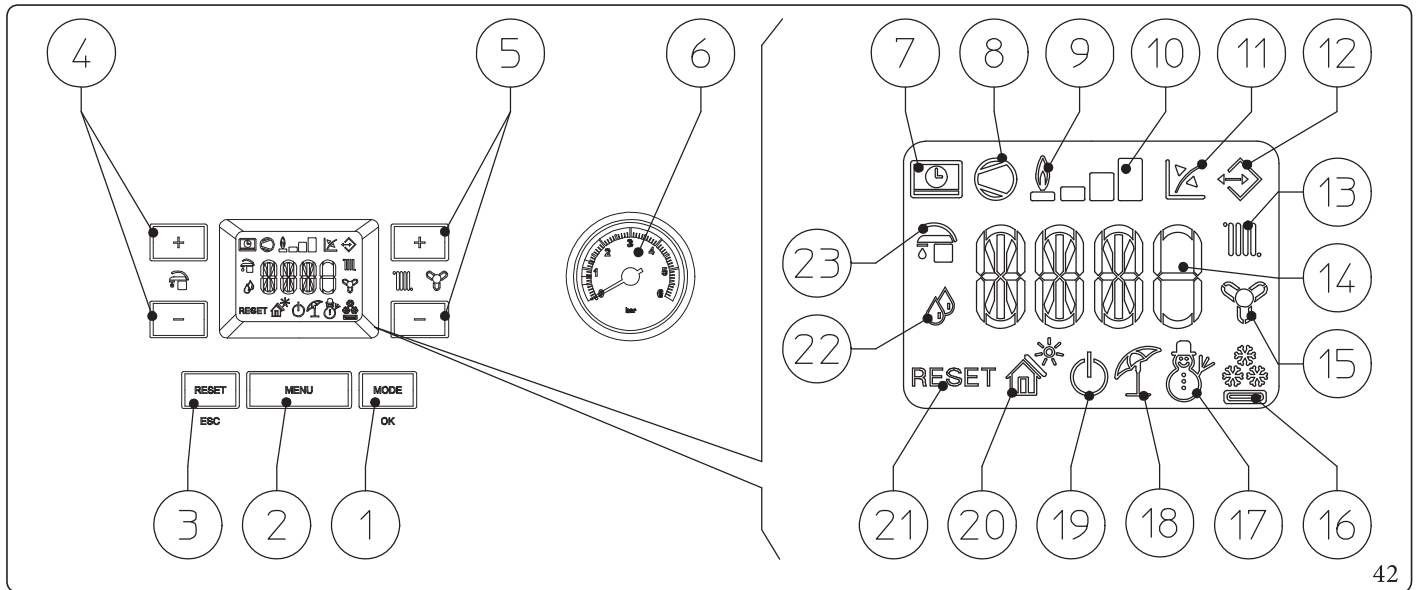

42



Key (Fig. 42):

- | | |
|--|--|
| <ul style="list-style-type: none"> 1 - Operating mode (winter - air conditioning - summer - stand-by - off) and parameter confirm button 2 - Menu selection button 3 - Reset and exit menu button 4 - Domestic hot water temperature selection buttons 5 - Heating system temperature selection buttons 6 - Indoor unit pressure gauge 7 - Remote control connection (optional) 8 - Outdoor unit in operation 9 - Not used on this model 10 - Dispensed output level 11 - Operation with external temperature probe active (optional) | <ul style="list-style-type: none"> 12 - Connection to other Immergas units 13 - Central heating room mode function active 14 - Temperature indicator, indoor unit info and error codes 15 - Room cooling mode operation active 16 - Operation in cooling mode 17 - Operation in winter mode 18 - Operation in summer mode 19 - Stand-by Mode 20 - Not used on this model 21 - Blocked indoor unit, it needs to be unblocked by pressing the "RESET" button 22 - Operation in dehumidification mode 23 - DHW production phase operating mode active |
|--|--|

2.4 SYSTEM USE





Before ignition, make sure the system is full of water, checking that the pressure gauge needle (6) points to a value between 1 and 1.2 bar and make sure that the chiller circuit has been filled as described in the outdoor unit instructions booklet.

- Open the gas cock upstream from the indoor unit;
- Press the button (1) until the display turns on, now the system will go back to the status it was in prior to shutdown (upon ignition the following are displayed in sequence: display segments all on, parameter A011, parameter A013).
- If the indoor unit is in stand-by, press the button (1) again to activate it. If this is not the case, go to the next point;
- Then press the button (1) in sequence and set the system to summer , winter , or air conditioning position .



The system, based on the settings you made, automatically handles which energy source to use, choosing the most efficient among those available to meet system requirements (see table at foot of page).

For example the same request (i.e. domestic hot water request) can be satisfied by the use of outdoor unit, shown by its symbol (), or by the heat generator ().

Summer

In this mode, the system only works to produce domestic hot water, the temperature is set using the buttons (4) and the corresponding temperature is shown on the display by the indicator (14).

In this mode the protection functions available in stand-by mode such as the antifreeze function etc are also guaranteed.

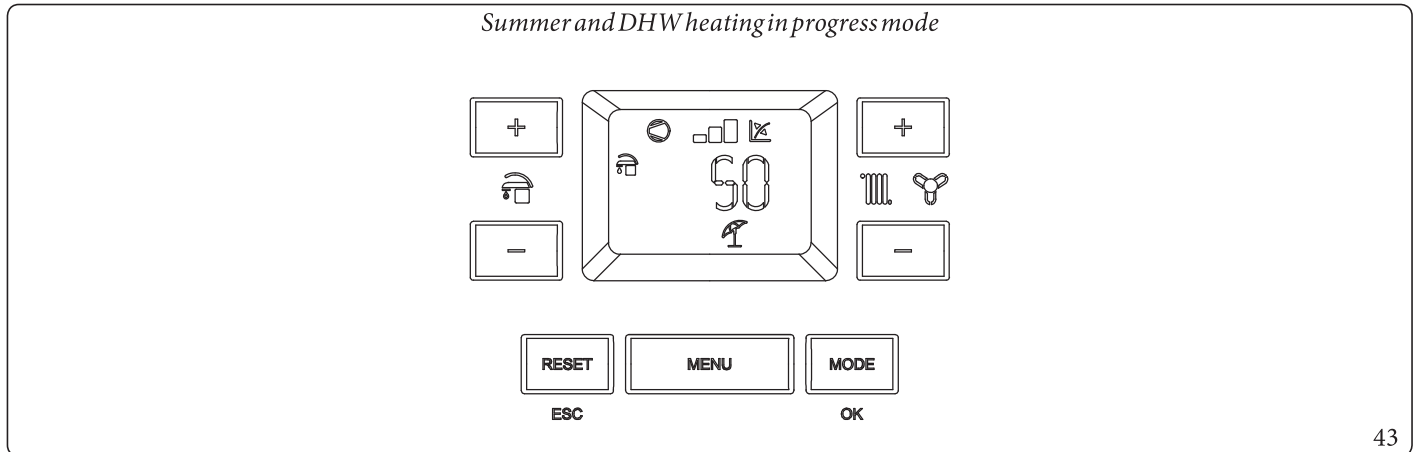

Winter

In this mode, the system works both to product domestic how water and room central heating.

The temperature of the DHW is always regulated via buttons (4), the central heating temperature is regulated via buttons (5) and the relative temperature is shown on the display by the indicator (14).

In this mode the protection functions available in stand-by mode such as the antifreeze function etc are also guaranteed.

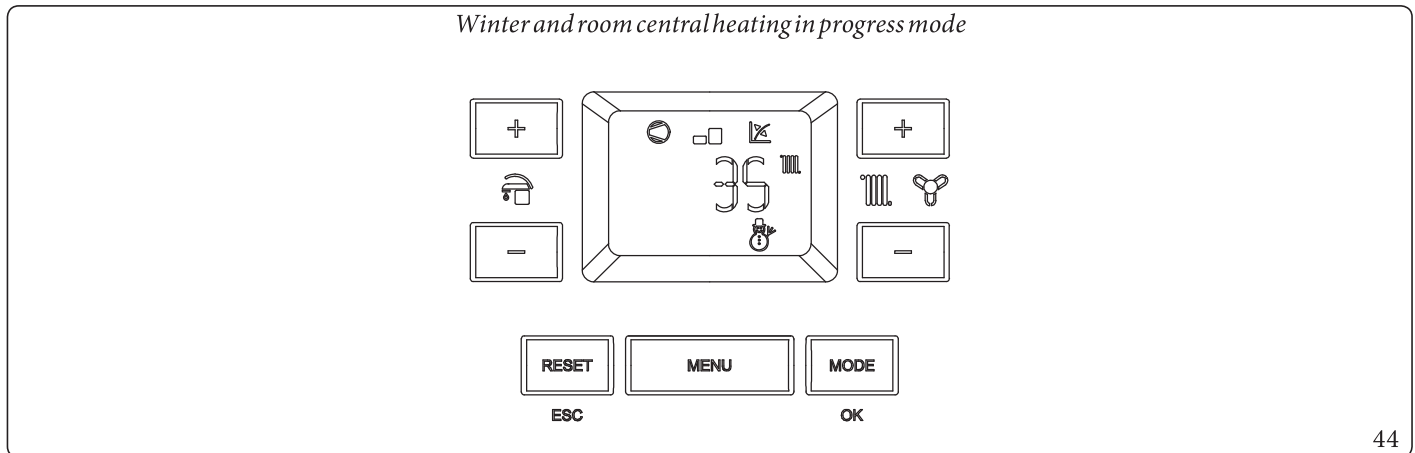

System's operating mode

As an example of operation, below is represented for practicality the outdoor unit operation mode.

		Heat pump	Heat generator
Summer	Production of Domestic Hot Water	OFF	ON
Winter	Production of Domestic Hot Water	OFF	ON
	Central heating	OFF	ON
		or	
	On	OFF	
	Production of DHW and central heating	OFF	ON (DHW)
or			
ON (Central heating)	ON (DHW)		
Air conditioning	Production of Domestic Hot Water	OFF	ON
	Room cooling	ON	OFF
		ON (Cooling)	ON (DHW)

Air conditioning

In this mode, the system works both to produce DHW and to cool the room.

The temperature of the DHW is always regulated via buttons (4), the central heating temperature is regulated via buttons (5) and the relative temperature is shown on the display by the indicator (14).

From here on, the system works automatically. If there are no requests (room central heating, DHW production or cooling), the system goes into the “stand-by” function.

Each time the outdoor unit ignites, the display shows the corresponding symbol (8) with the corresponding power scale (10).

In this mode the protection functions available in stand-by mode such as the antifreeze function etc are also guaranteed.

Air conditioning and room cooling in progress mode

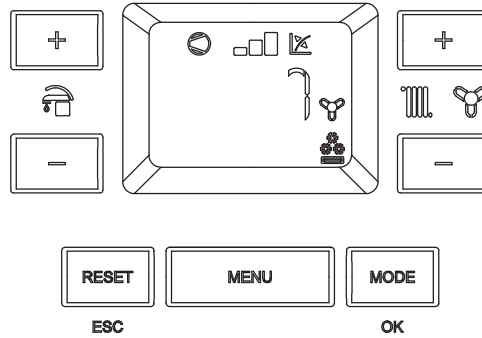

45

Operation with external probe

The system is set up to use the outdoor unit external probe or an optional external probe.

With the external probe connected, the system flow temperature for room heating and air conditioning is managed by the external probe based on the outdoor temperature measured (Parag. 1.15).

You can change the flow temperature by choosing the offset value in the specific user menu.

Dehumidify

If the system is coupled to a humidistat (optional) or a humidity temperature sensor or a remote zone panel (optional), you can manage the room humidity in summer air conditioning mode.

- If coupled to a humidistat, set the degree of humidity on the humidistat itself (see the instruction booklet).
- If coupled to a humidity temperature sensor, set the humidity percentage in the relative user menu.
- If coupled to a zone remote panel, set the humidity percentage in the relative user menu of the control panel or directly in the menu of the panel (see instruction booklet).

Air conditioning and Dehumidification active mode

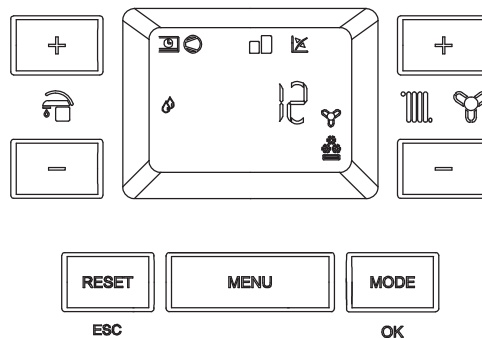

46



In central heating or cooling request mode, if the temperature of the water in the system meets the request, the system can work simply by activating the circulator pump.

“Stand-by” Mode

Press button (1) repeatedly until the symbol  appears. The system remains off from this moment, though the antifreeze, pump anti-block and 3-way function and signalling of any anomalies are guaranteed.



In these conditions the system must still be considered powered.

OFF mode

By holding the button (1) down for 8 seconds, the display switches-off and the indoor unit is off completely. In this mode, the safety functions are not guaranteed and the remote devices are disconnected.



In these conditions the indoor unit is considered still live even if there are no functions active.

“Automatic vent” mode

Every time the indoor unit is electrically powered, the system automatic vent function is activated (lasting 8 minutes). This function is displayed via a countdown signalled by the indicator (14).

During this period the DHW and CH functions are not active.

The “Automatic vent” function can be annulled by pressing the “Reset” button (3).

Display operation

The display lights up while the control panel is being used; after a set inactivity period, the brightness drops until only the active symbols are displayed. The lighting mode can be varied via parameter t8 in the P.C.B. programming menu.

System operating with outdoor unit disabled

You can disable the outdoor unit through a prearranged connection.

Disabling occurs when contact “S41” closes (Fig. 7).



This status is signalled by the flashing of the symbol “Outdoor unit operation in progress” (8) and the flashing of the anomaly code “194”.



In this condition the requests are satisfied by the heat generator.

Solar function

This function is automatically activated if the “Solar ignition delay” parameter is more than 0 seconds.

During a withdrawal, if the outlet water is hot enough or if there is “Solar ignition delay” time, the system does not switch on, the D.H.W. withdrawal symbol  appears on the display along with the flashing solar function symbol .

Summer Mode and Solar function active

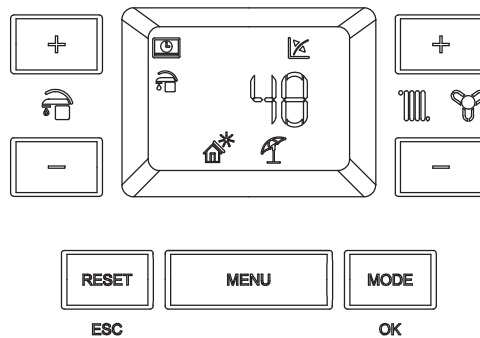

47

When the water supplied by the solar system is at a temperature lower than what is set, or if the “Solar ignition delay” time has elapsed, the system switches on to bring the DHW to the set temperature. At this point, the solar function symbol will go off.

2.5 FAULT AND ANOMALY SIGNALS

The indoor unit signals any anomalies by flashing a code on the display (14) according to the following table.

Error Code	Anomaly signalled	Cause	Indoor unit status/ Solution
E1	No ignition block	In the event of request of room central heating or domestic hot water production, the heat generator does not switch on within the preset time. Upon appliance commissioning or after extended downtime, it may be necessary to eliminate the block.	Press the Reset button (1) (4).
E2	Safety thermostat block (overheating), flame control or flue gas thermofuse anomaly	During normal operation, if a fault causes excessive overheating internally, the indoor unit goes into overheating block.	Press the Reset button (1) (2).
E4	Contacts resistance block	The P.C.B. detects a fault on the gas valve supply. Check its connection. (the anomaly is detected and displayed only in the event of a request).	(1) (4).
E5	Heat generator flow probe anomaly	The board detects an anomaly on the NTC heat generator flow probe.	The system does not start (1).
E6	DHW probe fault	The board detects an anomaly on the domestic hot water NTC probe. In this case the antifreeze function is also inhibited.	The heat generator continues to produce domestic hot water but not with optimal performance (1) (4).
E8	Maximum N° of resets	Number of allowed resets already performed.	Attention: the fault may be reset up to 5 times consecutively, after which the function is inhibited for at least one hour. One attempt is gained every hour for a maximum of 5 attempts. By switching the appliance on and off again, the 5 attempts are re-acquired.
(1) If the shutdown or fault persists, contact an authorised company (e.g. Authorised After-Sales Technical Assistance Centre)			
(2) The anomaly can only be verified in the list of errors in the “Information” menu.			
(3) The heat pump mode does not start, the heat generator stays active to satisfy the room heating and domestic hot water production requests.			
(4) The heat generator does not start, the heat pump mode stays active to satisfy the ongoing requests.			

Error Code	Anomaly signalled	Cause	Indoor unit status/ Solution
E 10	Insufficient system pressure	Water pressure inside the central heating circuit that is sufficient to guarantee the correct operation of the heat generator is not detected.	Check on the heat generator pressure gauge that the system pressure is between 1-1.2 bar and restore the correct pressure if necessary.
E 15	Configuration error	If the board detects an anomaly or incongruity on the electric wiring, the appliance will not start.	If normal conditions are restored, the heat generator restarts without having to be reset (1).
E 16	Fan anomaly	This occurs if the fan has a mechanical or electrical fault.	Press the Reset button (1) (4).
E 20	Parasite flame block	This occurs in the event of a leak on the detection circuit or anomaly in the flame control unit.	Press the Reset button (1) (4).
E 23	Heat generator return probe anomaly	The board detects an anomaly on the heat generator return NTC probe.	The system does not start (1) (4).
E 24	Push button control panel anomaly	The board detects an anomaly on the pushbutton panel.	If normal conditions are restored, the system restarts without having to be reset (1).
E 26	System flowmeter anomaly	The board detects an anomaly on the system flowmeter. Booster pump, if any, always working.	The system does not start (1) (3). Make sure the booster pump (optional) only activates when requested.
E 27	Circulation insufficient	This happens when the hydronic module overheats due to poor water circulation in the primary circuit. The causes can be: - low system circulation; check that no shut-off devices are closed on the central heating circuit and that the system is free of air (deaerated); - pump blocked; free the pump; - damaged flowmeter.	Check system circulation and flowmeter. Press the Reset button (1) (3).
(1) If the shutdown or fault persists, contact an authorised company (e.g. Authorised After-Sales Technical Assistance Centre)			
(2) The anomaly can only be verified in the list of errors in the “Information” menu.			
(3) The heat pump mode does not start, the heat generator stays active to satisfy the room heating and domestic hot water production requests.			
(4) The heat generator does not start, the heat pump mode stays active to satisfy the ongoing requests.			

INSTALLER

USER

MAINTENANCE TECHNICIAN

TECHNICAL DATA

Error Code	Anomaly signalled	Cause	Indoor unit status/ Solution
E 32	Mixed zone 2 probe anomaly	If the board detects an anomaly on the mixed zone 2 probe, the system cannot work in the affected area.	(1).
E 33	Mixed zone 3 probe anomaly	If the board detects an anomaly on the mixed zone 3 probe, the system cannot work in the affected area.	(1).
E 34	Safety thermostat intervention Mixed zone 2	During normal operation, if an anomaly causes excessive overheating of the flow temperature in the mixed zone 2, the unit indicates the malfunction.	The unit does not meet the zone central heating requirement (1).
E 35	Safety thermostat intervention Mixed zone 3	During normal operation, if an anomaly causes excessive overheating of the flow temperature in the mixed zone 3, the unit indicates the malfunction.	The unit does not meet the zone central heating requirement (1).
E 37	Low power supply voltage	This occurs when the power supply voltage is lower than the allowed limits for correct system operation.	If normal conditions are restored, the system restarts without having to be reset (1).
E 38	Loss of flame signal	This occurs when the heat generator is ignited correctly and the burner flame switches off unexpectedly; a new attempt at ignition is performed and if normal conditions are restored, the generator does not have to be reset.	If normal conditions are restored, the generator restarts without having to be reset (1) (2) (4).
E 43	Block due to loss of flame signal	This occurs if the "Flame signal loss" error occurs many times in a row within a preset period (E38).	Press the Reset button, before restarting, the heat generator will run a post-ventilation cycle (1) (4).
E 45	ΔT high	The board detects a sudden and unexpected rise in ΔT between the system flow probe and return probe, the heat generator limits the burner output to prevent damaging the condensing module; when the correct ΔT has been restored, the heat generator returns to normal operation.	If normal conditions are restored, the heat generator restarts without having to be reset (1) (4).
(1) If the shutdown or fault persists, contact an authorised company (e.g. Authorised After-Sales Technical Assistance Centre)			
(2) The anomaly can only be verified in the list of errors in the "Information" menu.			
(3) The heat pump mode does not start, the heat generator stays active to satisfy the room heating and domestic hot water production requests.			
(4) The heat generator does not start, the heat pump mode stays active to satisfy the ongoing requests.			

Error Code	Anomaly signalled	Cause	Indoor unit status/ Solution
E 49	High temperature block on heat generator return probe	This occurs when the heat exchanger return circuit reaches a temperature that is too high.	Make sure that water circulates properly in the heat generator and that the three-way valve works properly. Press the Reset button (1) (4).
E 50	External probe missing or faulty	In the event the external probe is not connected or is faulty, the anomaly is indicated.	Check the external probe connection. The system continues to operate with the external probe integrated in the external unit (1). In case of replacement of the external probe, repeat the installation operations.
E 54	Puffer probe anomaly (optional)	The board detects an anomaly on the puffer probe.	Puffer mode is disabled (1).
E 80	P.C.B. malfunction block	This occurs in the event of malfunctions of the P.C.B. that controls the gas valve.	Press the Reset button (1) (4).
E 98	Block - maximum no. of software errors	The maximum number of software errors possible has been reached.	Press the Reset button (1) (4).
E 99	General block	A heat generator anomaly has been detected.	Press the Reset button (1) (4).
E 121	Zone 1 device offline alarm	The device connected to zone 1 is offline.	(1).
E 122	Zone 2 device offline alarm	The device connected to zone 2 is offline.	(1).
E 123	Zone 3 device offline alarm	The device connected to zone 3 is offline.	(1).
E 125	Zone 1 room temperature probe anomaly	The zone 1 room probe has an out of range resistive value.	(1).
E 126	Zone 2 room temperature probe anomaly	The zone 2 room probe has an out of range resistive value.	(1).
(1) If the shutdown or fault persists, contact an authorised company (e.g. Authorised After-Sales Technical Assistance Centre)			
(2) The anomaly can only be verified in the list of errors in the “Information” menu.			
(3) The heat pump mode does not start, the heat generator stays active to satisfy the room heating and domestic hot water production requests.			
(4) The heat generator does not start, the heat pump mode stays active to satisfy the ongoing requests.			

INSTALLER

USER

MAINTENANCE TECHNICIAN

TECHNICAL DATA

Error Code	Anomaly signalled	Cause	Indoor unit status/ Solution
E 127	Zone 3 room temperature probe anomaly	The zone 3 room probe has an out of range resistive value.	(1).
E 129	Zone 1 humidity probe anomaly	Anomaly on the zone 1 humidity probe.	In addition to the humidity, the dew point is not calculated for the zone either (1). Zone humidity cannot be checked.
E 130	Zone 2 humidity probe anomaly	Anomaly on the zone 2 humidity probe.	In addition to the humidity, the dew point is not calculated for the zone either (1). Zone humidity cannot be checked.
E 131	Zone 3 humidity probe anomaly	Anomaly on the zone 3 humidity probe.	In addition to the humidity, the dew point is not calculated for the zone either (1). Zone humidity cannot be checked.
E 139	De-aeration in progress	Vent function in progress.	No demand can be made until the end of the function in progress (1).
E 142	Dominus offline alarm	Communication with Dominus is offline.	(1).
E 179	Liquid phase probe anomaly	The board detects an anomaly on the liquid phase NTC probe.	The system does not start (1) (3).
E 182	Outdoor unit alarm	An anomaly appears on the outdoor unit.	The system does not start, see the anomaly on the outdoor unit and its instructions booklet (1) (3).
E 183	Outdoor unit in test mode	A signal notifies that the outdoor unit is in test mode.	During this time, room heating/air conditioning and domestic hot water production requirements cannot be met.
E 184	Communication down with outdoor unit	A signal notifies an anomaly due to a communication problem between the indoor unit and the outdoor unit.	Have the electrical connection between the units checked (1) (3).
(1) If the shutdown or fault persists, contact an authorised company (e.g. Authorised After-Sales Technical Assistance Centre)			
(2) The anomaly can only be verified in the list of errors in the “Information” menu.			
(3) The heat pump mode does not start, the heat generator stays active to satisfy the room heating and domestic hot water production requests.			
(4) The heat generator does not start, the heat pump mode stays active to satisfy the ongoing requests.			

Error Code	Anomaly signalled	Cause	Indoor unit status/ Solution
E 185	Communication alarm	Communication anomaly between P.C.B. and ignition board.	Have the electrical connection between the components checked (1) (4).
E 186	Igniter voltage anomaly	An anomaly appears on the ignition board.	(1) (4).
E 187	Heat pump return probe anomaly	The board detects an anomaly on the heat pump return NTC probe.	(1) (3).
E 188	Request with temperature out of range	A heating or cooling request is made with an outdoor temperature exceeding the operating limits (Parag. 1.32).	(1) (3).
E 189	Time out alarm with interface board	If communication between the printed circuit boards is lost, an anomaly is signalled.	(1) (3).
E 190	Interface board alarm	An anomaly is reported on the interface board.	The system does not start (1). See communication board errors.
E 192	Heat pump flow probe anomaly	The board detects an anomaly on the NTC heat pump flow probe.	(1) (3).
E 193	Appliance in test mode	A signal notifies that the appliance is in test mode.	The system continues operating properly.
E 194	Outdoor unit disabled	A signal notifies that the outdoor unit has been disabled through the appropriate input in the terminal board.	The system continues operating properly.
E 195	Liquid phase probe low temperature anomaly	Too low temperature is detected in the liquid phase.	Check proper operation of the cooling circuit (1) (3).
E 196	High temperature block on heat pump flow	Excessively high temperature is detected in the flow circuit of the heat pump.	Check the hydraulic circuit (1) (3).
E 197	Interface board configuration error	An incorrect interface board configuration has been detected.	The system does not start (1)
(1) If the shutdown or fault persists, contact an authorised company (e.g. Authorised After-Sales Technical Assistance Centre)			
(2) The anomaly can only be verified in the list of errors in the “Information” menu.			
(3) The heat pump mode does not start, the heat generator stays active to satisfy the room heating and domestic hot water production requests.			
(4) The heat generator does not start, the heat pump mode stays active to satisfy the ongoing requests.			

INSTALLER

USER

MAINTENANCE TECHNICIAN

TECHNICAL DATA

Interface board anomalies list

If the outdoor unit is faulty, the error code is signalled on the control panel (Fig. 42) and on the interface board (see paragraph "Interface board - 7-segment display"). The failure is signalled in different ways.

On the control panel, the error is displayed with an "A" + error code.

On the interface board, the error is displayed with an "E" + error code, showing a sequence of two digits.

For example:

Error 101 is displayed as follows: E1 alternated with 01.

The following is the list of alarms as displayed on the control panel.

Error Code	Anomaly signalled	Indoor unit status / Solution
A101	Outdoor unit communication error	Check the communication cable to the outdoor unit. Check that the interface board works properly. (1)
A109	Communication error due to incorrect address of interface board	Check the address on the interface board. (1)
A122	MODBUS communication error	Check communication between the management board and interface boards. (1)
A162	EEPROM error	Replace the main board of the outdoor unit (1)
A177	Emergency error	(1)
A198	Error of thermal fuse terminal board (open)	(1)
A201	Communication error (failed coupling) between interface board and outdoor unit	Check the communication cable to the outdoor unit. Check that the interface board and main board of the outdoor unit work properly (1)
A202	Communication error (failed coupling) between indoor unit and interface board	Check the communication cable to the outdoor unit. Check that the interface board and main board of the outdoor unit work properly (1)
A203	Communication error between Inverter and main board of the outdoor unit	Check wiring of communication between the two boards. Replace the main board. Replace the inverter board (1)
(1) If the shutdown or fault persists, contact an authorised company (e.g. Authorised After-Sales Technical Assistance Centre)		

Error Code	Anomaly signalled	Indoor unit status/ Solution
A221	Outdoor unit air temperature sensor error	Check the position of the sensor. Check the relative wiring Replace the sensor (1)
A231	Condenser temperature sensor error	Check the position of the sensor. Check the relative wiring Replace the sensor (1)
A251	Discharge temperature sensor error	Check the position of the sensor. Check the relative wiring Replace the sensor
A320	Compressor sensor error (overload protection sensor)	Check the position of the sensor. Check the relative wiring Replace the sensor (1)
A403	Freezing detection (during cooling operation)	Check the chiller cycle. Check the temperatures of the plate heat exchanger (1)
A404	Protection of outdoor unit when in overload (during safety start-up, normal operating status)	Check the chiller cycle. Check the compressor connections. Check the resistances between the different phases of the compressor (1)
A407	Compressor not working due to high pressure	Check the chiller cycle (1)
A416	The compressor discharge is overheated	(1)
A430	Outdoor unit EEV operation error	(1)
A425	Not used on this model	(1)
A440	Central heating blocked (outdoor temperature beyond 35°C)	(1)

(1) If the shutdown or fault persists, contact an authorised company (e.g. Authorised After-Sales Technical Assistance Centre)

INSTALLER

USER

MAINTENANCE TECHNICIAN

TECHNICAL DATA

Error Code	Anomaly signalled	Indoor unit status/ Solution
A441	Cooling blocked (outdoor temperature below 9°C)	(1)
A458	Error of outdoor unit fan no.1	1
A461	Compressor start-up error (Inverter)	Check the chiller cycle. Check the compressor connections. Check the resistances between the different phases of the compressor (1)
A462	Inverter total current overload error	Check the inlet current. Check the refrigerant charge. Check normal operation of the fan. (1)
A463	Compressor overheated sensor	Check the compressor sensor. (1)
A464	Inverter IPM current overload error	Check the compressor connections and its normal operation. Check the refrigerant charge. Check whether there are obstacles around the outdoor unit. Check whether the service valve is open. Check whether the installation pipes are mounted properly. (1)
A465	Compressor overload error	Check the compressor connections and its normal operation. Check the resistances between the different phases of the compressor. (1)
A466	Low voltage error of DC circuit	Check the input voltage. Check the power connections. (1)
A467	Compressor rotation error	Check the compressor connections. Check the resistances between the different phases of the compressor. (1)

(1) If the shutdown or fault persists, contact an authorised company (e.g. Authorised After-Sales Technical Assistance Centre)

Error Code	Anomaly signalled	Indoor unit status/ Solution
A468	Current sensor error (inverter)	Check the main board. (1)
A469	Voltage sensor error of DC circuit (inverter)	Check the power connector of the inverter board. Check the connectors RY21 and R200 of the inverter board. (1)
A470	EEPROM reading/writing error of outdoor unit	Check the main board. (1)
A471	EEPROM reading/writing error of outdoor unit	Check the main board. (1)
A474	Inverter temperature sensor error	Replace inverter board (1)
A475	Error of outdoor unit fan no.2 (where present)	Check the wiring. Check that the fan is powered. Check the board fuses. (1)
A484	PFC overload	Check inductances. Replace inverter board. (1)
A485	Incoming current sensor error	Replace inverter board. (1)
A500	IPM overheated	Check temperature of inverter board. Switch the machine off. Wait for the inverter to cool down. Switch the machine back on. (1)
A554	Gas leak error	Check that the coolant is charged Check the liquid sensor of the indoor unit Check whether the service valve is open Check whether the installation pipes are mounted properly. (1)
A590	Inverter board error	Check normal operation of the main board. Replace the main board (1)
A601	Not present	(1)
(1) If the shutdown or fault persists, contact an authorised company (e.g. Authorised After-Sales Technical Assistance Centre)		

INSTALLER

USER

MAINTENANCE TECHNICIAN

TECHNICAL DATA

Error Code	Anomaly signalled	Indoor unit status/ Solution
A604	Not present	(1)
A653	Not present	(1)
A654	Not present	(1)
A899	Not present	(1)
A900	Not present	(1)
A901	Not used	Indoor unit error Check indoor unit (1)
A902	Not used	Indoor unit error Check indoor unit (1)
A903	Not used	Indoor unit error Check indoor unit (1)
A904	Not used	Indoor unit error Check indoor unit (1)
A906	Not used	Indoor unit error Check indoor unit (1)
A911	Not used	Indoor unit error Check indoor unit (1)
A912	Not used	Indoor unit error Check indoor unit (1)
A916	Not used	Indoor unit error Check indoor unit (1)
A919	Not used	Indoor unit error Check indoor unit (1)
(1) If the shutdown or fault persists, contact an authorised company (e.g. Authorised After-Sales Technical Assistance Centre)		

2.6 PARAMETERS AND INFORMATION MENU

Information menu

Pressing the “MENU” button (2), the display cyclically shows the “Data” menu, “User” menu and a menu protected by a “0000” access code with the first flashing digit reserved for a qualified technician.

To access an individual menu, once it appears, press the “OK” button (1).

To scroll through the menu items and to edit the values, use the heating temperature control buttons (5). Pressing the “OK” button (1) confirms the parameter, while pressing the “ESC” button (3) goes back to the previous menu or exits.

A minute after the last operation, the system automatically exits any of the menus.



The menus of the control panel, found in the booklet, refer to rev. 4.0 of the P.C.B. firmware.

Data Menu.

Parameter ID	Description	Range
D01	Combustion signal (x0.1 μA)	0 ÷ 99 μA
D02	Temperature of the instant heating thermal generator flow outgoing from the heat generator primary exchanger	0 ÷ 99°C
D03	Instant output temperature from the DHW heat exchanger	0 ÷ 99°C
D04	Value calculated for system setting	5 ÷ 80°C
D05	Value set for DHW setting	10 ÷ 65°C
D06	Outdoor temperature (if the outdoor unit external probe is connected or if the optional external probe is available)	-20 ÷ 50°C
D07	DHW inlet probe temperature	0 ÷ 99°C
D08	Heat pump return water temperature	0 ÷ 99°C
D09	List of the last five anomalies (to scroll the list press “OK” (1))	
D10	Anomaly list reset. Once “D10” is displayed, press “OK”.	
D12	Heat generator pump operating speed	0 ÷ 100%
D13	Presence of DHW request	OFF - ON
D14	Circulator pump flow rate	0 ÷ 9999 l/h
D15	Fan operating speed	0 ÷ 9999 rpm
D20	System flow temperature	0 ÷ 99°C
D22	Heat generator 3-way (DHW = domestic hot water, CH = central heating)	DHW - CH
D23	Boiler return temperature	0 ÷ 99°C
D24	Chiller circuit liquid temperature	0 ÷ 99°C
D25	Zone 2 flow temperature (if configured)	0 ÷ 99°C

Parameter ID	Description	Range
D 26	Probe for primary solar storage (puffer)	0 ÷ 99 °C
D 27	Primary circuit pressure switch	OFF - ON
D 28	Heat pump circulator DHW speed	0 ÷ 100 %
D 29	Flue probe	0 ÷ 100 °C
D 34	Heat pump disabling	OFF - ON
D 35	Solar system inlet	OFF - ON
D 36	Not used	
D 41	Relative humidity zone 1 (if zone 1 humidity sensor active)	0 ÷ 99 %
D 42	Relative humidity zone 2 (if zone 2 humidity sensor active)	0 ÷ 99 %
D 43	Zone 1 humidistat (if zone 1 humidistat active)	OFF - ON
D 44	Zone 2 humidistat (if zone 2 humidistat active)	OFF - ON
D 45	Dehumidifier zone 1	OFF - ON
D 46	Dehumidifier zone 2	OFF - ON
D 47	Zone 1 circulator pump	OFF - ON
D 48	Zone 2 circulator pump	OFF - ON
D 49	Central heating / cooling system separation 3-way (CL = cooling, HT = heating)	CL - HT
D 51	Zone 1 remote panel	OFF - ON
D 52	Zone 2 remote panel	OFF - ON
D 53	System setting with remote connection in zone 1	5 ÷ 80 °C
D 54	System setting with remote connection in zone 2	5 ÷ 80 °C
D 55	Zone 1 thermostat	OFF - ON
D 56	Zone 2 thermostat	OFF - ON
D 61	System model definition (MP = Magis Pro; MCI = Magis Combo; MCP = Magis Combo Plus)	MP - MCI - MCP
D 62	Communication with outdoor unit interface board	OFF - ON
D 63	Communication with other Immergas devices	OFF - ON
D 71	External unit operating frequency	0 ÷ 150 Hz
D 72	Compressor temperature	-20 ÷ 200 °C
D 73	Compressor discharge temperature	-20 ÷ 100 °C
D 74	Evaporator coil temperature	-20 ÷ 100 °C
D 75	Outdoor unit compressor absorption (make sure the value reading refers to the inverter and therefore not a value read with an amperometric clamp)	0 ÷ 10 A

Parameter ID	Description	Range
D 76	Outdoor unit fan speed	0 ÷ 100 rpm
D 77	Electronic expansion valve position	0 ÷ 2000
D 78	4-way side (CL = cooling, HT = heating)	HT / CL
D 79	Temperature detected by the external probe of the outdoor unit	-55° ÷ +45°C
D 80	Heat pump status (reserved for Technical Assistance Service)	0 ÷ 255
D 91	P.C.B. software version	30
D 92	Ignition board software version	
D 97	Heat pump demand status (reserved for Technical Assistance Service)	0 ÷ 999
D 98	Thermal generator demand status (reserved for Authorised After-Sales Technical Assistance Centre)	0 ÷ 999
D 99	System state (reserved to Authorised After-Sales Technical Assistance Centre)	0 ÷ 999
D101	Zone 3 flow temperature (if applicable)	1 ÷ 99
D102	Zone 3 relative humidity (if available)	1 ÷ 99
D103	Zone 3 humidistat (if present)	OFF - ON

INSTALLER

USER

MAINTENANCE TECHNICIAN

TECHNICAL DATA

User Menu.

Parameter ID	Description	Range	Default	Customised value	
U01	Zone 2 heating flow set point in case of no thermal regulation ("R01" = OFF).	20 ÷ 80°C	25		
U02	Zone 2 cooling flow set point in case of no thermal regulation ("R01" = OFF)	5 ÷ 25°C	20		
U03	Zone 1 central heating offset	You can edit the flow temperature with respect to the external probe regulation curve in central heating mode (Parag. 1.16, Offset value)	- 15 ÷ + 15°C	0	
U04	Zone 2 central heating offset		- 15 ÷ + 15°C	0	
U05	Zone 1 cooling offset	You can edit the flow temperature with respect to the external probe regulation curve in cooling stage (Parag. 1.16, Offset value)	- 15 ÷ + 15°C	0	
U06	Zone 2 cooling offset		- 15 ÷ + 15°C	0	
U07	Zone 1 humidity setting	The humidity temperature sensor (optional) defines room humidity in the corresponding area	30 ÷ 70%	50	
U08	Zone 2 humidity setting		30 ÷ 70%	50	
U11	Night function	Activating the function allows you to reduce the compressor frequency during the outdoor unit operation in the time slot set in the U 12 and U 13 parameters. Make sure the additional power sources needed to meet potential requirements that may present themselves during active operation are available.	OFF - ON	OFF	

Parameter ID	Description	Range	Default	Customised value
U 12	Night function enabling time	0 ÷ 23	0	
U 13	Night function disabling time	0 ÷ 23	0	
U 14	Zone 3 heating flow set point in case of no thermal regulation ("R01" = OFF).	20 ÷ 80 °C	25	
U 15	Zone 2 cooling flow set point in case of no thermal regulation ("R01" = OFF)	5 ÷ 25 °C	20	
U 16	Zone 3 central heating offset	- 15 ÷ + 15 °C	0	
U 17	Zone 3 cooling offset	- 15 ÷ + 15 °C	0	
U 18	Zone 3 humidity setpoint	30 ÷ 70	50	
U 21	Hour setting (internal clock)	0 - 23 hours		
U 22	Minutes setting (internal clock)	0 - 59 minutes		
U 23	Day of the week	Mo-Tu-We- Th- Fr-Sa-Su		
U 24	Current day	1 ÷ 31		
U 25	Current month	1 ÷ 12		
U 26	Current year	00 ÷ 99		
U 32	Start time of the DHW recirculation function (do not use)	0 - 23 hours		
U 33	Start time of the DHW recirculation function (do not use)	0 - 23 hours		
U 50	Venting	In the case of new central heating systems and in particular mode for floor systems, it is very important that de-aeration is performed correctly. The function consists of the cyclic activation of the pump (100 s ON, 20 s OFF) and the 3-way valve (120 s D.H.W., 120 s heating system). The function lasts for 18 hours and it is possible to stop it by pressing "ESC" and setting the function on "OFF". Activation of the function is signalled by the countdown shown on the indicator (14).	OFF - ON	OFF



The parameters referring to zone 2 can only be displayed if there is a zone 2 on the system and it is configured correctly.



The parameters referring to zone 3 can only be displayed if there is a zone 3 on the system and it is configured correctly.

2.7 INDOOR UNIT SHUTDOWN

Switch the indoor unit off by putting it in “off” mode, disconnect the omnipolar switch outside of the indoor unit and close the gas cock upstream from the appliance.

Never leave the indoor unit switched on if left unused for prolonged periods.

2.8 RESTORE CENTRAL HEATING SYSTEM PRESSURE

1. Periodically check the system water pressure (the indoor unit’s pressure gauge hand must indicate a value between 1 and 1.2 bar).
2. If the pressure is less than 1 bar (with the system cold), you must restore it using the cock located at the bottom of the unit (Parag. 1.36).
3. Close the cock after the operation.
4. If the pressure reaches values around 3 bar, there is a risk of tripping the safety valve (in this case, remove water from a radiator air vent valve until a pressure of 1 bar is achieved, or ask for assistance from professionally qualified personnel).
5. In the event of frequent pressure drops, contact qualified staff for assistance to eliminate the possible system leakage.

2.9 DRAINING THE SYSTEM

1. Ensure that the filling cock is closed.
2. Open the draining cock (Parag. 1.36).
3. Open all vent valves.
4. At the end, close the emptying cock.
5. Close all previously opened vent valves.



If fluid containing glycol was added to the system circuit, make sure it is recovered and disposed of in accordance with standard EN 1717.

2.10 EMPTYING THE D.H.W. CIRCUIT

To do this, always close the domestic cold water inlet upstream of the appliance.

Open any domestic hot water tap to discharge the pressure from the circuit.

2.11 ANTIFREEZE PROTECTION

The indoor unit has an antifreeze function of the heat pump circulator that switches on when the water temperature drops below 8 °C.

The indoor unit has a further anti-freeze function that automatically switches on the heat generator or operation in heat pump mode when the temperature drops below 4°C (standard protection up to a minimum temperature of -5 °C).

All information relative to the antifreeze protection is stated in (Parag. 1.5).

In order to guarantee the integrity of the appliance and the domestic hot water heating system in areas where the temperature drops below zero, we recommend protecting the central heating system using anti-freeze liquid and installing the Immergas Antifreeze Kit in the indoor unit.

In the case of prolonged inactivity (second case), we also recommend that:

- to switch off the power supply;
- completely empty the central heating circuit and the indoor unit domestic hot water circuit. In systems that are drained frequently, filling must be carried out with suitably treated water to eliminate hardness that can cause lime-scale.

2.12 CLEANING THE CASE

1. Use damp cloths and neutral detergent to clean the indoor unit casing.



Never use abrasive or powder detergents.

2.13 PERMANENT SHUTDOWN

In the event of permanent shutdown of the indoor unit, contact professional staff for the procedures and ensure that the electrical, water and gas supply lines are shut off and disconnected.

2.14 USE OF THE REMOTE ZONE PANEL (OPTIONAL)

For general operation of the zone remote panel, see the relative instruction booklet.

The settings on the remote panel, such as operating mode, flow setting, humidity setting etc. are synchronised with those on the control panel.

Moreover, the control panel is not disabled if there is any zone remote panel.

INSTALLER

USER

MAINTENANCE TECHNICIAN

TECHNICAL DATA

3 INSTRUCTIONS FOR MAINTENANCE AND INITIAL CHECK

3.1 GENERAL RECOMMENDATIONS

INSTALLER



Operators who install and service the appliance must wear the personal protective equipment (PPE) required by applicable law.
The list of possible PPE is not complete as they are indicated by the employer.

USER



Before carrying out any maintenance work, make sure that:

- you have disconnected the power to the appliance;
- you have discharged the pressure from the system and domestic hot water circuit.



Supply of spare parts

The device's warranty shall be rendered null and void if unapproved or unsuitable parts are used for maintenance or repairs. These will also compromise the product's compliance, and the said product may no longer be valid and fail to meet the current regulations. In regard to the above, only use original Immergas spare parts when replacing components.



If additional documentation needs to be consulted for extraordinary maintenance, contact the Authorised After-Sales Service.

MAINTENANCE TECHNICIAN



The appliance operates with R32 refrigerant gas.
This gas is ODOURLESS.

Pay the utmost attention

Strictly follow the instruction handbook of the outdoor unit before installation and any type of operation on the chiller line.



R32 refrigerant gas belongs to the low flammability refrigerant category: class A2L according to standard ISO 817. It guarantees high performance with low environmental impact. The new gas reduces the potential environmental impact by one third compared to R410A, having less effect on global warming (GWP 675).

TECHNICAL DATA

3.2 INITIAL CHECK

To commission the package, you must:

- make sure that the type of gas used corresponds to indoor unit settings;
- check connection to a 230V-50Hz power mains, correct L-N polarity and the earthing connection;
- make sure the central heating system is filled with water and the indoor unit pressure gauge reads a pressure of 1-1.2 bar;
- check that the air vent valve cap is open and that the system is well-vented;
- switch the indoor unit on and check correct ignition;
- check the Δp gas values in domestic hot water and central heating modes;
- check the CO₂ flow rate in the flue:
 - maximum
 - minimum
- check activation of the safety device in the event of no gas, as well as the relative activation time;
- make sure the chiller circuit has been filled according to what is described in the outdoor unit instructions booklet;
- check the activation of the main switch located upstream of the indoor unit;
- check that the intake and/or exhaust terminals are not blocked;
- ensure activation of all adjustment devices;
- seal the gas flow regulation devices (if the settings are changed);
- ensure production of domestic hot water;
- check the tightness of the hydraulic circuits;
- check ventilation and/or aeration of the installation room where provided.



Even if just one single safety check provides a negative result, do not commission the system.

3.3 YEARLY APPLIANCE CHECK AND MAINTENANCE



The following checks and maintenance should be performed once a year to ensure operation, safety and efficiency of the appliance over time.

- Clean the flue side of the heat exchanger.
- Clean the main burner.
- Check the correct positioning, integrity and cleanliness of the detection and ignition electrode; remove any oxide present.
- If deposits are detected in the combustion chamber they must be removed and the heat exchanger coils must be cleaned using nylon or broomcorn brushes; it is forbidden to use brushes made of metal or other materials that may damage the combustion chamber. It is also forbidden to use alkaline or acid detergents.
- Check the integrity of the insulating panels inside the combustion chamber and if damaged replace them.
- Visually check for water leaks or oxidation from/on connections and traces of condensate residues inside the sealed chamber.
- Check the contents of the condensate drain trap.
- Visually check that the siphon is properly filled with condensate and top it up if necessary.
- Check that there are no material residues in the condensate drain siphon clogging the condensate passage; also check that the entire condensate drainage circuit is clear and efficient.
- In the event of obstructions (dirt, sediment, etc.) with consequent leakage of condensate in the combustion chamber, one must replace the insulating panels.
- Check that the burner and gas manifold seal gaskets are intact and perfectly efficient, otherwise replace them. In any case the gaskets must be replaced at least every two years, regardless of their state of wear.
- Check that the burner is intact, that it has no deformations or cuts and that it is properly fixed to the combustion chamber lid; otherwise it must be replaced.
- Visually check that the water safety drain valve is not blocked.
- Check that, after discharging the system pressure and bringing it to zero (read on boiler pressure gauge), the expansion vessel pressure is at 1.0 bar.
- Check that the system static pressure (with system cold and after refilling the system by means of the filling valve) is between 1 and 1.2 bar.

- Check visually that the safety and control devices have not been tampered with and/or shorted, in particular:
- temperature safety thermostat;
- system pressure switch.
- Check the condition and integrity of the electrical system and in particular:
 - the power supply wires must be housed in the cable glands;
 - there must be no traces of blackening or burning.
- Check correct lighting and operation.
- Ensure correct calibration of the burner in domestic water and central heating phases.
- Check correct operation of control and adjustment devices and in particular:
 - system control thermostat intervention;
 - domestic hot water control thermostat intervention.
- Check sealing efficiency of gas circuit and the internal system.
- Check the intervention of the device against no gas ionisation flame control. Intervention time must be less than 10 seconds.
- Check chiller line connections.
- Check mesh filter on system return
- Check the correct flow rate on plate heat exchanger.
- Check the integrity of the internal insulation.

 We recommend regularly inspecting the finned air coils to check the level of fouling.

This depends on the environment where the unit is installed. The level of fouling will be worse in urban and industrial sites, as well as near trees that lose their leaves.

There are two maintenance levels to clean the coils:

- If the air heat exchangers are encrusted, clean them gently with a brush in a vertical direction.
- Turn off the fans before working on the air heat exchangers.
- To perform this type of intervention, stop the unit only if the maintenance considerations allow it.
- Perfectly clean air heat exchangers ensure an optimal operation of the unit. When the air heat exchangers begin to encrust, they must be cleaned. The cleaning frequency depends on the season and location of the unit (ventilated, wooded, dusty, etc.).

-
-  Clean the air coil using suitable products.
 Do not use pressurised water without a large diffuser. Do not use high-pressure cleaners for Cu/Cu and Cu/Al air coils.
 Concentrated and/or rotating water jets are strictly prohibited.
 Never use fluid with a temperature above 45°C to clean the air heat exchangers.
 Proper and frequent cleaning (approx. every three months) prevents 2/3 of corrosion problems.
-

 In addition to yearly maintenance, one must also check the energy efficiency of the thermal system, with frequency and procedures that comply with the indications of the technical regulations in force.

3.4 HYDRAULIC DIAGRAM

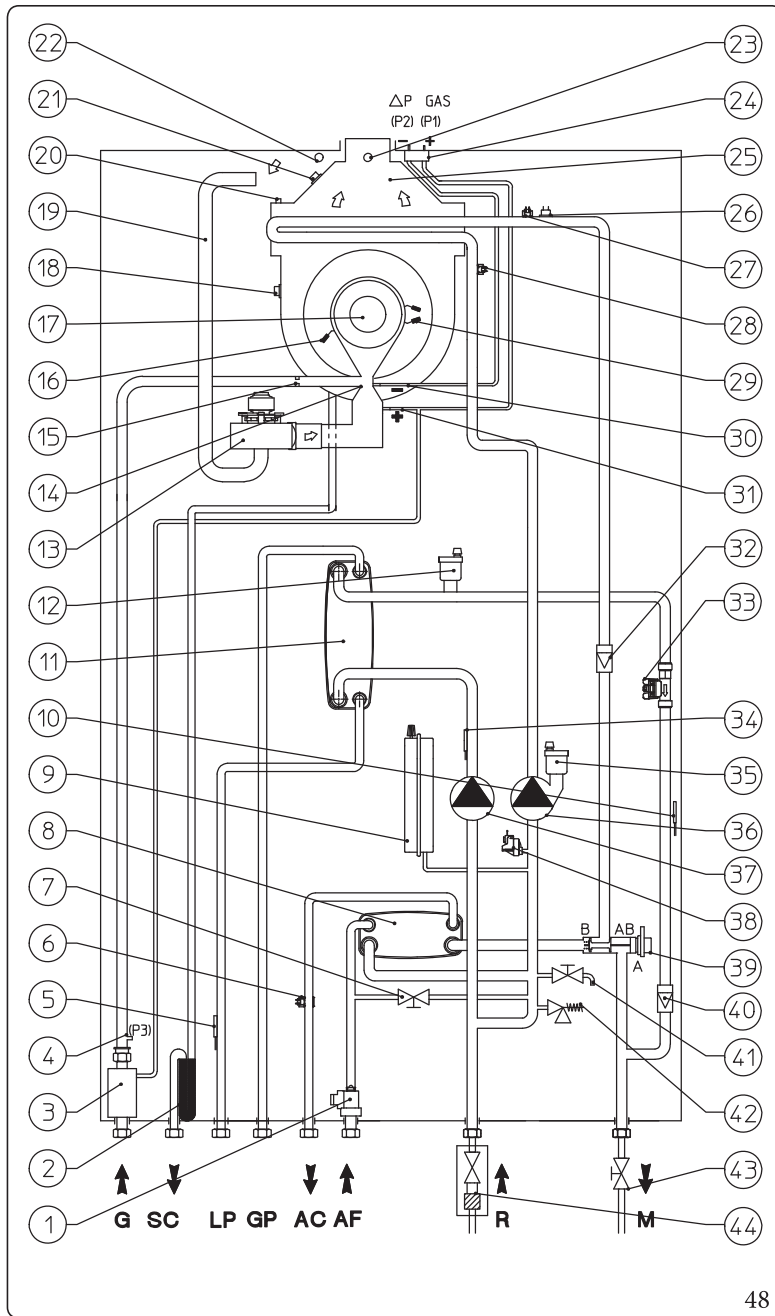

Key (Fig. 48):

- 1 - D.H.W. flow switch
- 2 - Condensate drain trap
- 3 - Gas valve
- 4 - Gas valve outlet pressure point (P3)
- 5 - Liquid phase detection probe
- 6 - D.H.W. probe
- 7 - System filling cock
- 8 - D.H.W. heat exchanger
- 9 - System expansion vessel
- 10 - Heat pump flow probe
- 11 - Water-gas plate exchanger
- 12 - Air vent valve
- 13 - Fan
- 14 - Air/gas Venturi manifold
- 15 - Gas nozzle
- 16 - Detection electrode
- 17 - Burner
- 18 - Flue gas thermofuse
- 19 - Air intake pipe
- 20 - Manual air vent valve
- 21 - Heat exchanger safety thermofuse
- 22 - Air sample point
- 23 - Flues sample point
- 24 - ΔP gas pressure point
- 25 - Flue hood
- 26 - Safety thermostat
- 27 - Heat generator flow probe
- 28 - Heat generator return probe
- 29 - Ignition electrodes
- 30 - Venturi negative signal (P2)
- 31 - Venturi positive signal (P1)
- 32 - One-way valve
- 33 - System flow-meter
- 34 - Heat pump return probe
- 35 - Air vent valve
- 36 - Heat generator circuit circulator
- 37 - Heat pump circuit circulator
- 38 - System pressure switch
- 39 - Heat generator three-way valve
- 40 - One-way valve
- 41 - System draining cock
- 42 - 3 bar safety valve
- 43 - System shut-off cock
- 44 - System shut-off cock with filter

- G - Gas supply
- SC - Condensate drain
- LP - Chiller line - liquid phase
- GP - Chiller line - gaseous phase
- AC - Domestic hot water outlet
- AF - Domestic hot water inlet
- R - System return
- M - System flow

INSTALLER

USER

MAINTENANCE TECHNICIAN

TECHNICAL DATA

3.5 WIRING DIAGRAM

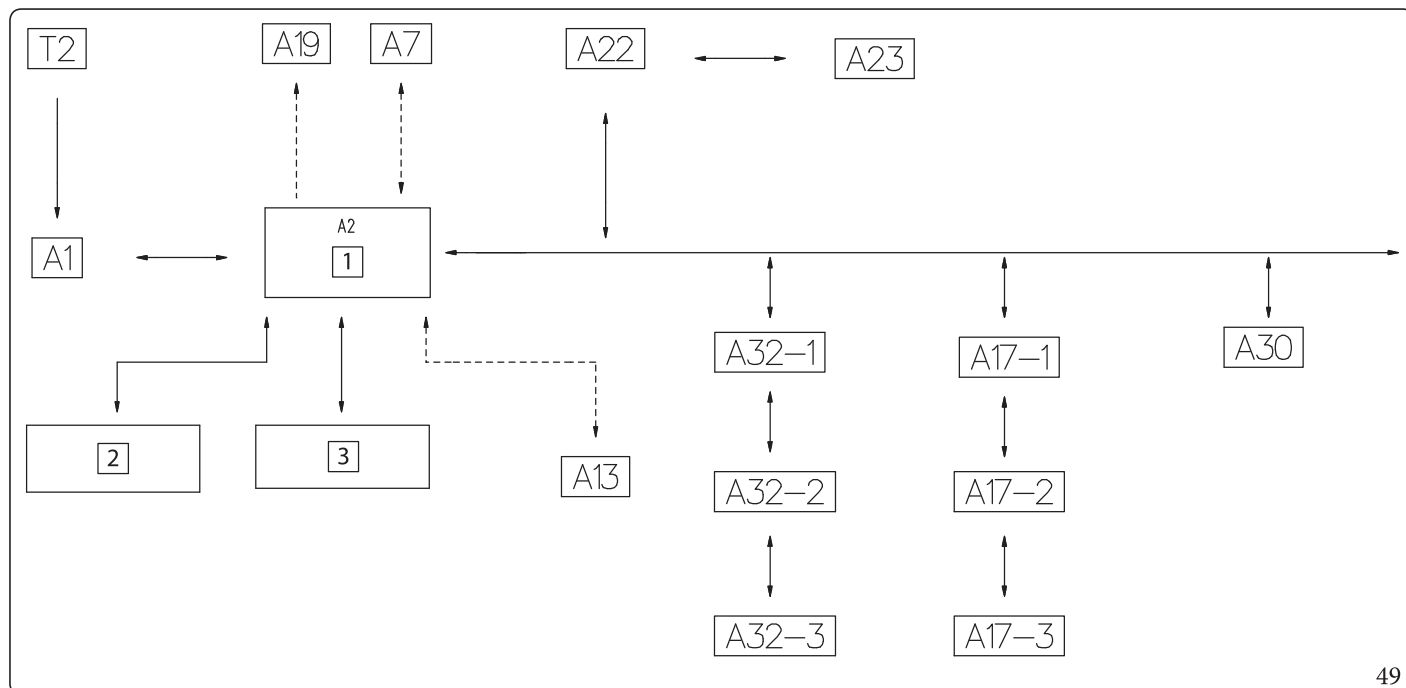

49

Key (Fig. 49):

- 1 - P.C.B. adjustment
- 2 - Electrical connections terminals of the vertical terminal block
- 3 - Electrical connections terminals of the horizontal terminal block
- A1 - Ignition board
- A2 - P.C.B.
- A7 - Three-relay board (optional)
- A13 - System manager (optional)
- A17-1 - Modbus zone 1 temp./humidity probe (optional)
- A17-2 - Modbus zone 2 temp./humidity probe (optional)
- A17-3 - Modbus zone 3 temp./humidity probe (optional)
- A19 - Two-relay board (optional)
- A22 - Interface board
- A23 - Outdoor unit
- A30 - Dominus (optional)
- A32-1 - Zone 1 remote control (optional)
- A32-2 - Zone 2 remote control (optional)
- A32-3 - Zone 3 remote control (optional)
- T2 - Ignition transformer

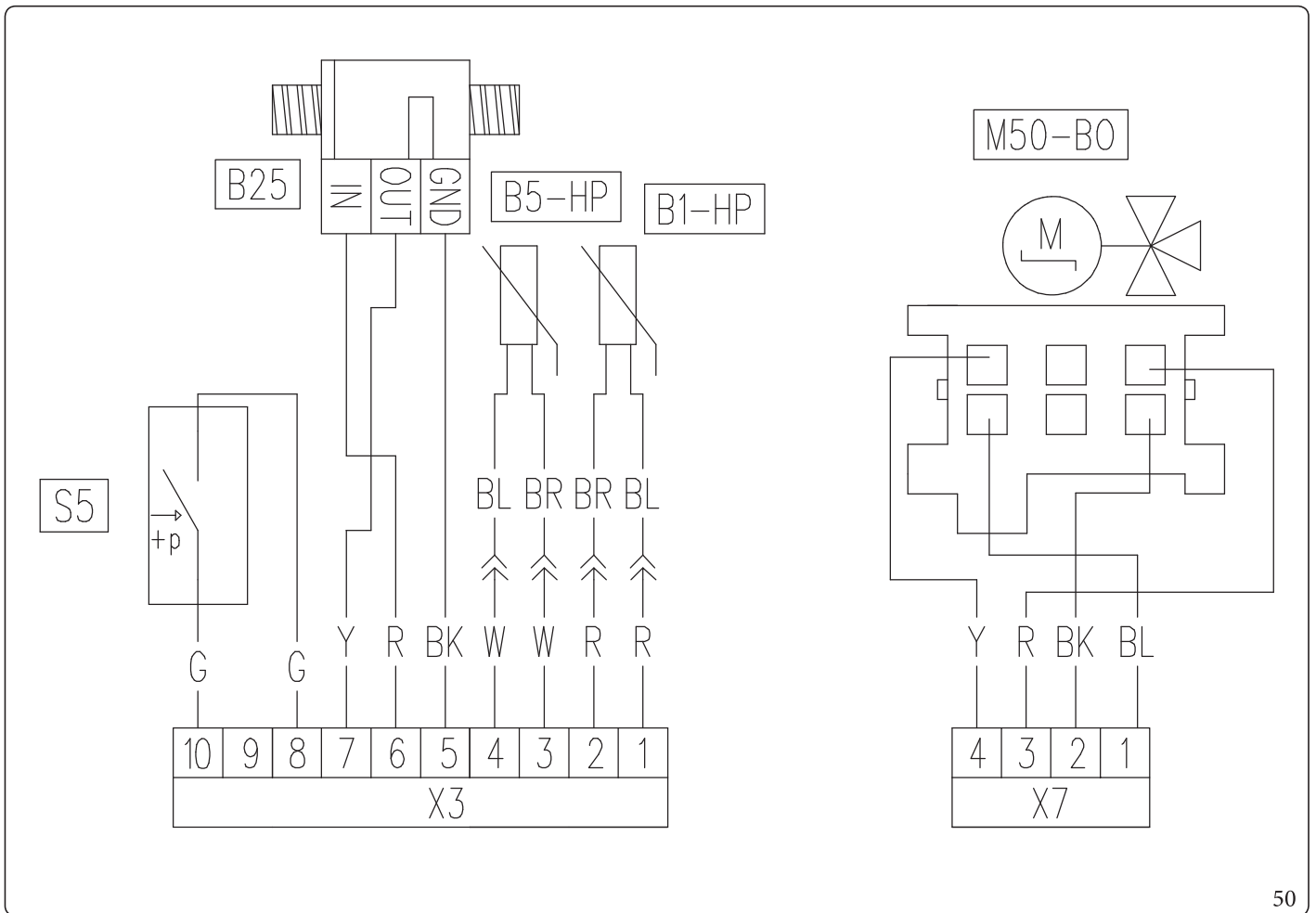

50

Key (Fig. 50):

- A2 - P.C.B.
- B1-HP - HP flow probe
- B5-HP - HP return probe
- B25 - System flow-meter
- M50-B0 - Heat unit three-way valve.
- S5 - System pressure switch

Colour code key (Fig. 50):

- BK - Black
- BL - Blue
- BR - Brown
- G - Green
- GY - Grey
- G/Y - Yellow/Green
- P - Purple
- PK - Pink
- R - Red

INSTALLER

USER

MAINTENANCE TECHNICIAN

TECHNICAL DATA

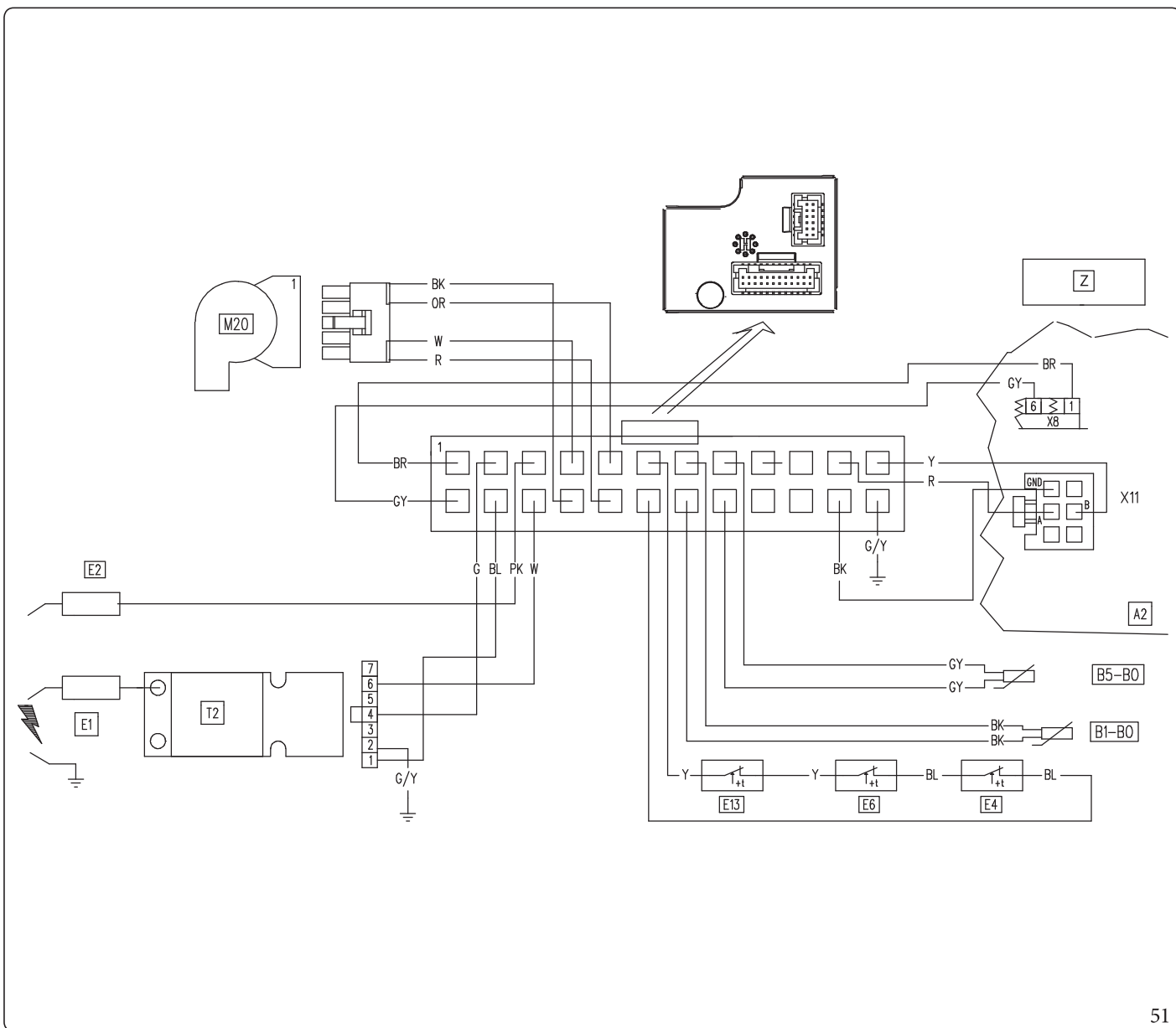

Key (Fig. 51):

- A2 - P.C.B.
- B1-B0 - Temperature control unit flow probe
- B5-B0 - Temperature control unit return probe
- E1 - Ignition glow plug
- E2 - Detection electrode
- E4 - Safety thermostat
- E6 - Flue safety thermostat
- E13 - Heat exchanger safety thermostat
- M20 - Fan
- T2 - Ignition transformer
- Z - Control panel electrical connections compartment terminal board

Colour code key (Fig. 51):

- BK - Black
- BL - Blue
- BR - Brown
- G - Green
- GY - Grey
- G/Y - Yellow/Green
- OR - Orange
- P - Purple
- PK - Pink
- R - Red
- W - White
- Y - Yellow
- W/BK - White/Black

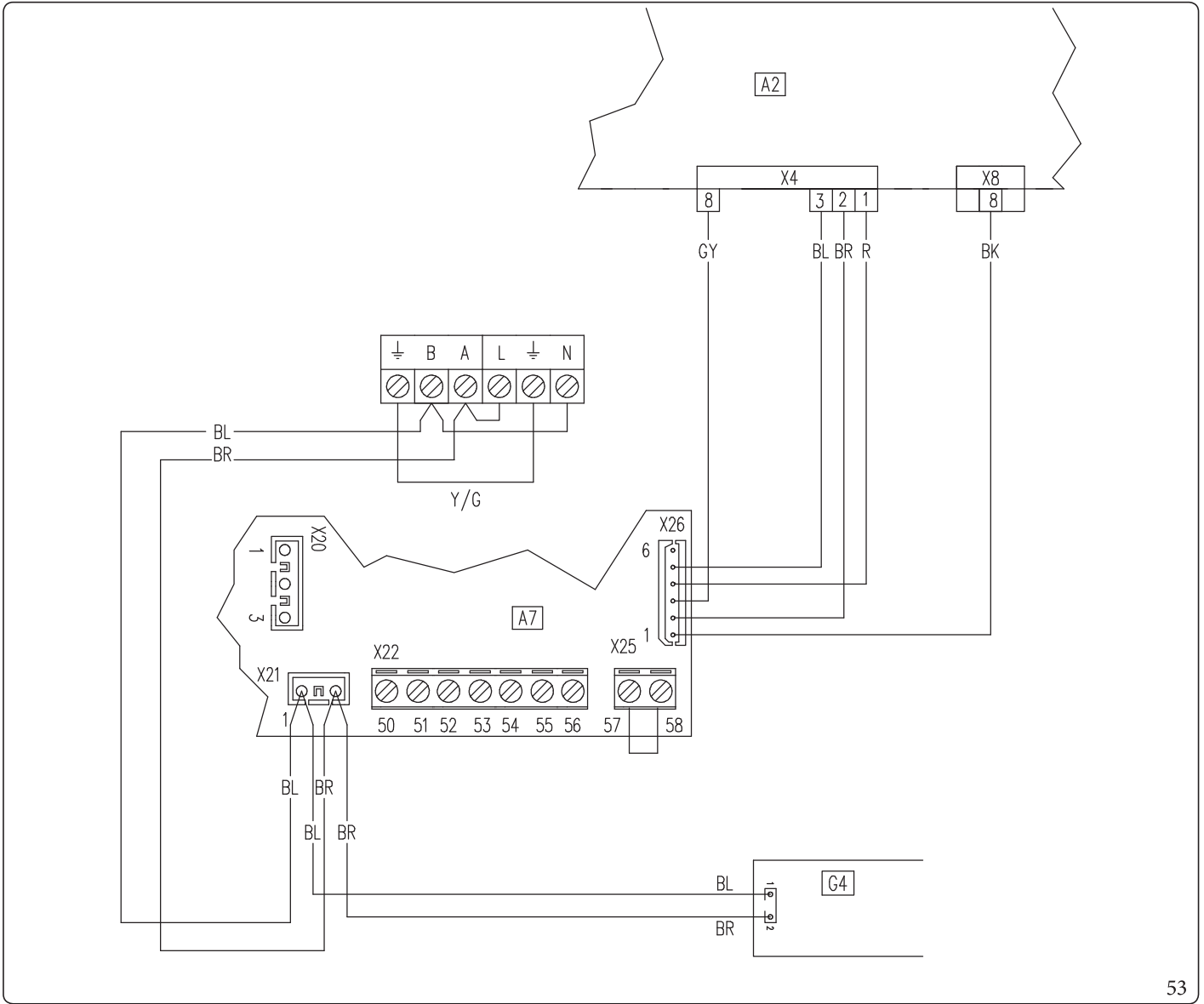

Key (Fig. 53):

- A2 - P.C.B.
- A7 - Three-relay board (optional)
- G4 - 24 Vdc power supply unit

Colour code key (Fig. 53):

- BK - Black
- BL - Blue
- BR - Brown
- G - Green
- GY - Grey
- G/Y - Yellow/Green
- P - Purple
- PK - Pink
- R - Red

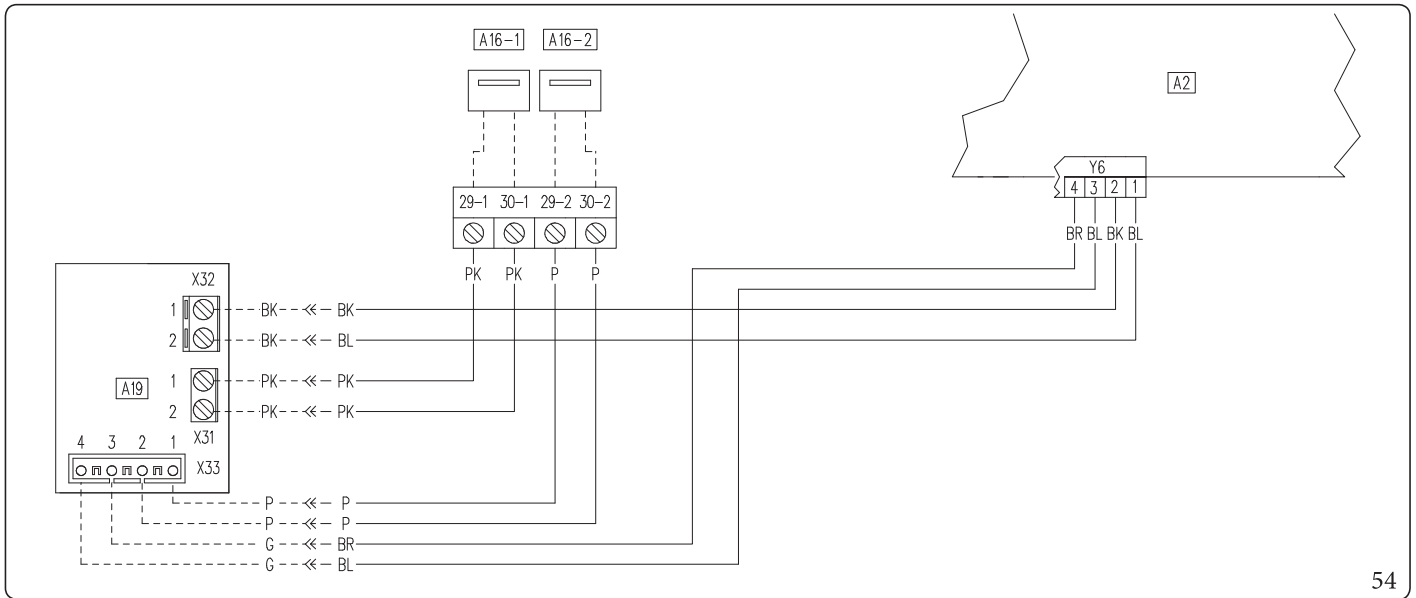

54

Key (Fig. 54):

- A2 - P.C.B.
- A16-1 - Zone 1 dehumidifier (optional)
- A16-2 - Zone 2 dehumidifier (optional)
- A19 - Two-relay board (optional)

Colour code key (Fig. 54):

- BK - Black
- BL - Blue
- BR - Brown
- G - Green
- GY - Grey
- G/Y - Yellow/Green
- OR - Orange
- P - Purple
- PK - Pink
- R - Red
- W - White
- Y - Yellow
- W/BK - White/Black

INSTALLER

USER

MAINTENANCE/TECHNICIAN

TECHNICAL DATA

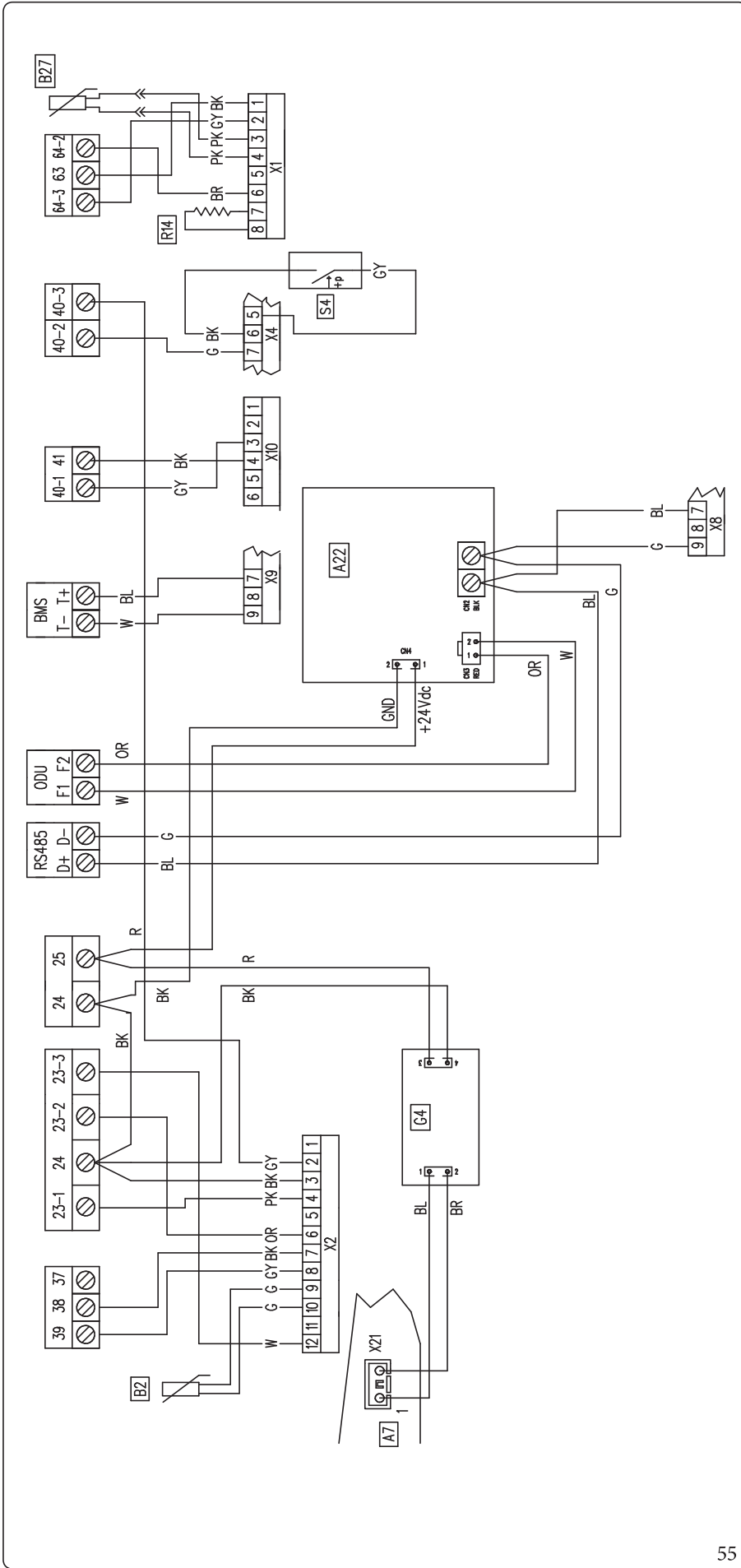

Key (Fig. 55):

- A7 - Three-relay board (optional)
- A22 - Outdoor unit interface board
- B2 - D.H.W. probe
- B27 - Liquid phase probe
- G4 - 24 Vdc power supply unit
- R14 - Resistance configuration
- S4 - D.H.W. flow switch

Colour code key (Fig. 55):

- BK - Black
- BL - Blue
- BR - Brown
- G - Green
- GY - Grey
- GY/GY - Yellow/Green
- OR - Orange
- P - Purple
- PK - Pink
- R - Red
- W - White
- Y - Yellow
- W/BK - White/Black

P.C.B.

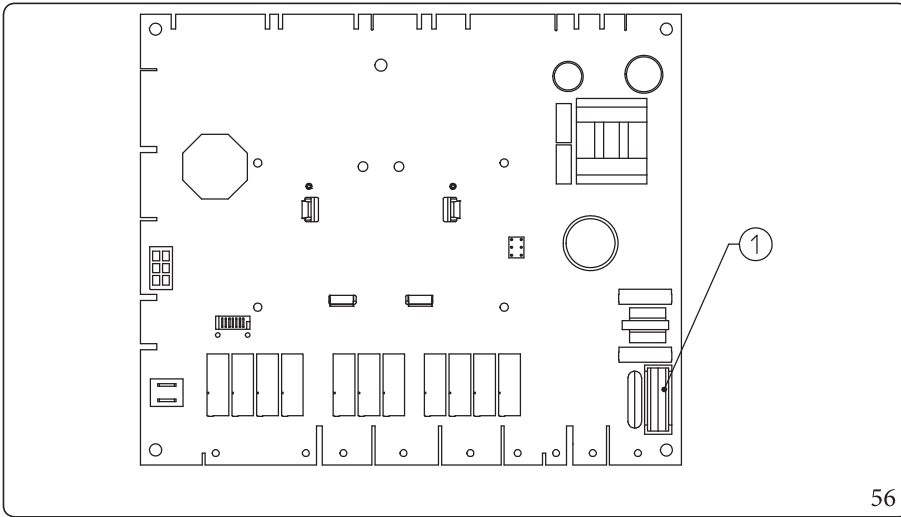

56

Key (Fig. 56):

1 - F3.15A H250V fuse

Interfaceboard - settings switch

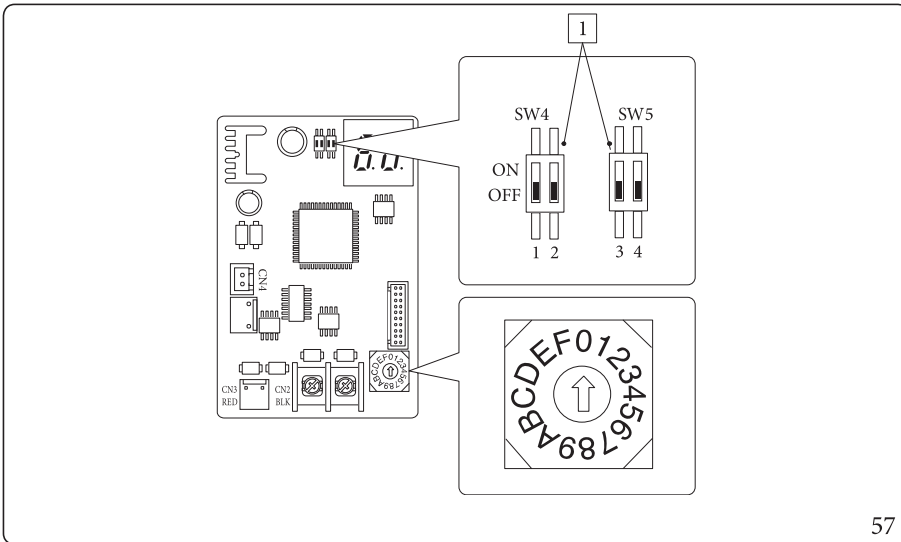

57

Key (Fig. 57):

1 - Factory setting: do not change

Interfaceboard - indicator LED

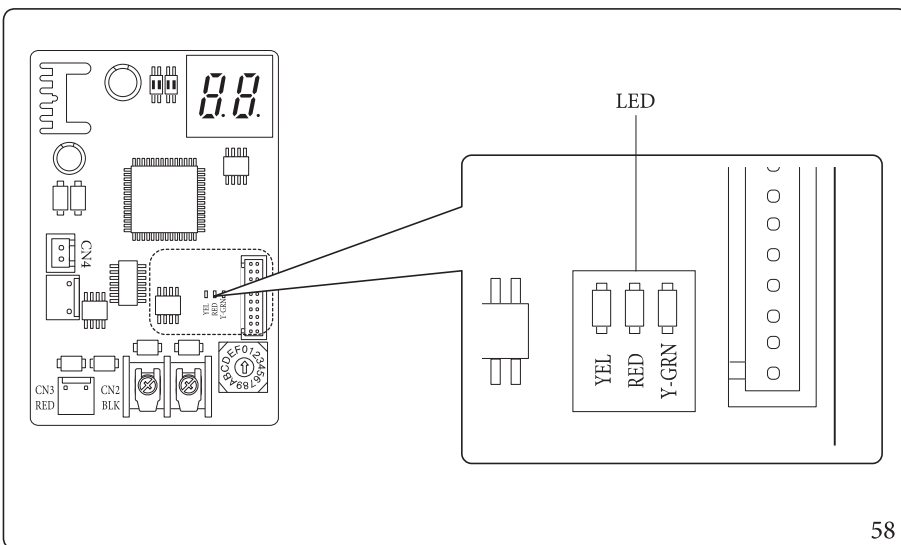

58

Key (Fig. 58):

Red LED flashing = Communication between interface board and P.C.B. valid

Green LED flashing = Communication between interface board and outdoor unit valid

Yellow LED = Not Used

INSTALLER

USER

MAINTENANCE TECHNICIAN

TECHNICAL DATA

Interface board - 7-segment display

During normal operation, the display shows “A0” for 1 second, followed by “30” for 1 second:

	SEGMENTS
VALID COMMUNICATION	A0 ▷ 30

In case of an error of the outdoor unit, a sequence of two digits at a time is displayed: “E” plus outdoor unit error code:

ERROR CODES	SEGMENTS
E101	E1 ▷ 01

3.6 SYSTEM FILTER

The indoor unit has a filter on the system return cock to keep the system in good operating conditions.

Periodically and when necessary, the filter can be cleaned as described below (Fig. 59).

Close the tap (3) with a size 12 spanner and tap (5) by hand, drain out the water contained in the indoor unit using the draining valve (4).

Open the cap (1) and clean the filter (2).

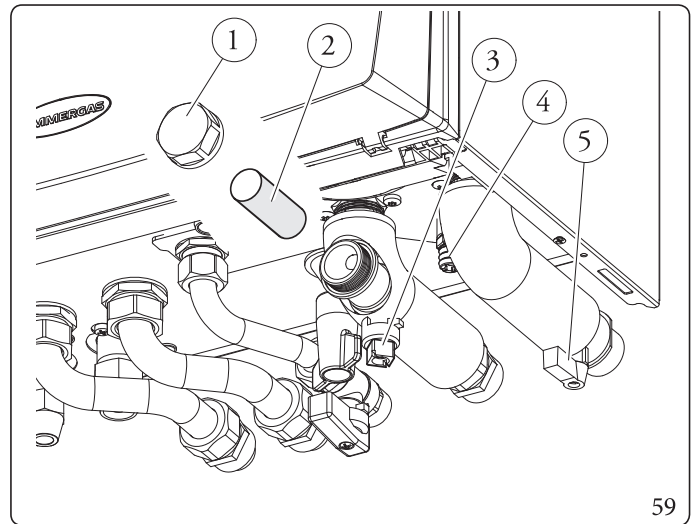

59

3.7 TROUBLESHOOTING



Maintenance operations must be carried out by an authorised company (e.g. Authorised After-Sales Technical Assistance Centre).

Red pump LED

There can be three possible causes for this anomaly:

Trouble	Possible causes	Solutions
Low power supply voltage	After about 2 seconds, the LED switches from green to red and the pump stops.	Wait for the power supply voltage to rise; when the pump restarts, the LED will turn green again with a delay of about one second. Note: The flow rate decreases as the supply voltage decreases.
Rotor seized	Powering the pump with the rotor seized, after about 4 seconds the LED switches from green to red,	Carefully act on the screw in the middle of the head to manually release the crankshaft; circulation starts up immediately after the rotor is released and the LED switches from red to green after about 10 seconds.
Electrical error		Check that there is no fault on the pump (on its wiring or electronics).

Trouble	Possible causes	Solutions
Smell of gas	Caused by leakage from gas circuit pipelines.	Check sealing efficiency of gas intake circuit.
Repeated ignition blocks	No gas. Condensate drain clogged.	Check the presence of pressure in the network and that the gas addition cock is open. Restore/release the function of the condensate drain, checking that the condensate has not affected: combustion components, fan and gas valve. Check the function of the condensate sensor.
Irregular combustion or noisiness	Dirty burner, clogged primary heat exchanger, incorrect combustion parameters, intake-exhaust terminal not correctly installed.	Check the indicated components.
Frequent trips of the overheating safety device thermostat function.	Lack of water in the boiler, poor water circulation in the system or blocked circulating pump (Par. 1.34).	Check on the pressure gauge that the system pressure is within established limits. Check that the radiator valves are not closed and also the functionality of the pump.
Siphon blocked	Dirt or combustion products deposited inside.	Check that there are no residues of material blocking the flow of condensate.
Heat exchanger blocked.	Obstruction of the siphon.	Check that there are no residues of material blocking the flow of condensate.
Abnormal noises in the system	Air in the system.	Check the opening of the cap of the air vent valve (Par. 1.36). Make sure the system pressure and expansion vessel pre-charge values are within the set limits. The factory-set pressure values of the expansion vessel must be 1.0 bar, the value of system pressure must be between 1 and 1.2 bar.
Abnormal noises in the condensation module	Air in the module.	Use the manual air vent valve (Par. 1.36) to eliminate any air present in the condensation module. When the operation has been performed, close the manual vent valve.
Poor production of D.H.W.	Clogged condensing module or D.H.W. exchanger.	Contact After-Sales Assistance Service that has procedures to clean the module or D.H.W. heat exchanger.
Poor production of D.H.W.	DHW heat exchanger clogged.	Contact the Authorised After-Sales Assistance Service that has procedures to clean the D.H.W. heat exchanger.

INSTALLER

USER

MAINTENANCE TECHNICIAN

TECHNICAL DATA

3.8 GAS VALVE

The gas valve (Fig. 60) is equipped with functioning status signal LED (5), the LEDs are under the transparent protection cover (4).

Colour	Status
Off	Gas valve not powered
Green	Gas valve powered and working
Red	Gas valve powered and not working

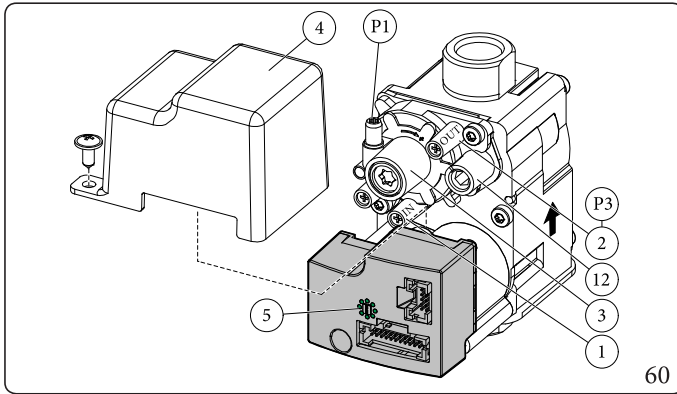

Key (Fig. 60):

- 1 - Gas valve inlet pressure point
- 2 - Gas valve outlet pressure point
- 3 - Off/Set adjustment screw
- 4 - Transparent protection cover
- 5 - Gas valve status signal display
- 12 - Outlet gas flow rate adjuster

3.9 CONVERTING THE HEAT GENERATOR TO OTHER TYPES OF GAS



The gas conversion operation must be carried out by an authorised company (e.g. Authorised Technical Assistance Service).

If the appliance needs to be converted to a different gas type to that specified on the data plate, request the relative conversion kit for quick and easy conversion.

To convert to another type of gas the following operations are required:

- disconnect power to the appliance;
- replace the nozzle positioned between the gas pipe and the air/gas mixing sleeve, taking care to remove the voltage from the appliance during this operation;
- re-power the appliance;
- calibrate fan speed (Parag. 3.10);
- adjust the correct air/gas ratio (Parag. 3.11);
 - seal the gas flow rate regulation devices (if settings are modified);
- after completing the conversion, apply the sticker, contained in the conversion kit, near the data nameplate. Using an indelible marker pen, delete the data relative to the old type of gas.

These adjustments must be made with reference to the type of gas used, following that given in the table in the indoor unit manual.

Checks following conversion to another type of gas.

After having made sure that the conversion is complete and that the calibration has been successful, you must make sure that:

- there is no flame in the combustion chamber;
- the burner flame is not too high or low and that it is stable (does not detach from burner);



The pressure testers used for calibration should be perfectly closed and there should be no leaks from the gas circuit.



Maintenance operations must be carried out by an authorised company (e.g. Authorised After-Sales Technical Assistance Centre).

3.10 FAN SPEED CALIBRATION



Verification and calibration are necessary, in the case of transformation to other types of gas, in the extraordinary maintenance phase with replacement of the PCB, air/gas circuit components or in the case of installations with flue extraction systems, with horizontal concentric pipe measuring more than 1 metre.

The indoor unit heat output is correlated to the length of the air intake and flue exhaust pipes.

This decreases with the increase of pipe length.

The indoor unit leaves the factory adjusted for minimum pipe length (1m). It is therefore necessary, especially in the case of maximum pipe extension, to check the Δp gas values after at least 5 minutes of the burner operating at nominal heat output, when the temperatures of the intake air and exhaust flue gas have stabilised.

Adjust the nominal and minimum output in the domestic hot water and central heating modes according to the values in the table in the indoor unit manual using the differential manometers connected to the Δp gas pressure points (Det. 9-Fig. 41).

Enter the configurations menu and regulate the following parameters (Parag. 3.12);

- DHW minimum no. of fan revs "S00";
- DHW maximum no. of fan revs "S01";
- delete ignition stage "S02".

Listed below are the default settings featured:

Parameter ID	Description		Range	Default	Customised value
S00	DHW minimum no. of fan revs	Operating speed of the fan at minimum DHW output	900 ÷ 1500 (RPM)	G20: 1300	
				G30: 1300	
				G31: 1300	
S01	DHW maximum no. of fan revs	Operating speed of the fan at maximum DHW output	3000 ÷ 6100 (RPM)	G20: 5100	
				G30: 4800	
				G31: 5400	
S02	Ignition phase fan speed	Operating speed of the fan during the ignition phase	0 - 100%	16	

3.11 ADJUSTMENT OF THE AIR-GAS RATIO

Calibration of minimum CO₂ (minimum central heating output).

Enter the chimney sweep phase without withdrawing domestic hot water and take the selector switches to minimum until "0" is seen on the display.

To have an exact value of CO₂ the technician must insert the sampling probe to the bottom of the sample point, then check that the CO₂ value is that specified in the table, otherwise adjust the screw (Det. 3Fig. 60)(Off-Set adjuster).

To increase the CO₂ value, turn the adjustment screw (3) in a clockwise direction and vice versa to decrease it.

Calibration of maximum CO₂ (nominal central heating output).

On completion of the adjustment of the minimum CO₂ keeping the chimney sweep function active, take the heating selector switch to maximum (increase the value until "99" is seen on the display).

To have an exact value of CO₂ the technician must insert the sampling probe to the bottom of the sample point, then check that the CO₂ value is that specified in the table below, otherwise adjust the screw (Det. 12Fig. 60)(gas flow rate regulator).

To increase the CO₂ value, turn the adjustment screw (12) in a clockwise direction and vice versa to decrease it.

At every adjustment variation on the screw 12 it is necessary to wait for the heat generator to stabilise itself at the value set (about 30 sec.).

Gastype	CO ₂ to nominal Q.	CO ₂ to minimum Q.
G20	9.6% (±0,5)	8.6% (±0,5)
G30	12.3% (-)	11.2% (-)
G31	10.6% (±0,5)	10% (±0,5)

3.12 P.C.B. PROGRAMMING

The water heater is set up for possible programming of several operation parameters. By modifying these parameters as described below, the system can be adapted according to specific needs.

To access the programming phase, press the “MENU” button (2) until the “Password” menu appears. Enter the password, modify the numerical values using the “central heating regulation” buttons (5) and confirm with the “OK” button (1).

Once you have accessed programming, you can scroll through the parameters in the “System” menu.

Using the “central heating regulation” button, select the parameter and edit the value.

To save the parameter change, press the “OK” button.

Wait for 1 minute or press the “ESC” button (3) to exit programming mode.

Parameter ID	Description		Range	Default	Customised value
A 03	Minimum speed	Defines the minimum operating speed of the heat pump circulator	0 ÷ 100 %	100	
A 04	Maximum fixed speed	Defines the maximum operating speed of the heat pump circulator	45 ÷ 100 %	100	
A 05	Circulator mode	0 = Fixed (See Parag. “Circulation pump”)	0 - 25 °C	0	
		5 - 25 K = ΔT constant (See Parag. “Circulation pump”)			
A 11	Outdoor unit model	Establishes the outdoor unit model paired with the hydronic module. If set to OFF, only the integrated generators are activated.	OFF - 4 - 6 - 9	9	
A 12	System vent	Enables the automatic vent function.	OFF - ON	ON	
		This function activates as soon as the unit is powered.			

Parameter ID	Description		Range	Default	Customised value
A 13	Number of zones	Defines the number of zones in the heating system	1 – 2 – 3	1	
A 14	Zone 2 max temperature	Defines the maximum temperature acceptable by zone 2	20 ÷ 80 °C	45	
A 15	Zone 3 max temperature	Defines the maximum temperature acceptable by zone 3	20 ÷ 80 °C	45	
A 16	Zone 1 humidity sensor	Defines the type of control on zone 1 humidity	SE = Temperature - humidity sensor	ST	#V#
			ST = Humidistat		
			RP - Remote panel		
			RPH = Remote panel with humidistat		
A 17	Zone 2 humidity sensor	Defines the type of control on zone 2 humidity	SE = Temperature - humidity sensor	ST	#V#
			ST = Humidistat		
			RP - Remote panel		
			RPH = Remote panel with humidistat		
A 18	Heat generator minimum circulator speed	Defines the minimum operating speed of the heat generator circulator	55 ÷ 100 %	75	
A 19	Heat generator maximum fixed circulator speed	Defines the maximum operating speed of the heat generator circulator	55 ÷ 100 %	100	
A 21	BMS communication address	Defines the communication protocol between the indoor unit and the outdoor unit	1 ÷ 247	11	
A 22	BMS communication setting	OFF = BMS communication protocol on 485; use if connected to optional Immergas devices.	OFF - 485 - UC	OFF	
		485 = Do not use			
		UC = Do not use			

INSTALLER

USER

MAINTENANCE TECHNICIAN

TECHNICAL DATA

Parameter ID	Description		Range	Default	Customised value
A 23	Zone 3 humidity sensor	Defines the type of control on zone 3 humidity	SE = Temperature - humidity sensor	ST	#V#
			ST = Humidistat		
			RP - Remote panel		
			RPH = Remote panel with humidistat		
A 30	Dominus enabling	Allows you to enable the Dominus remote device	OFF - ON	OFF	
A 31	Zone 1 room thermostat	Defines the temperature control in zone 1	RT = Room thermostat	RT	
			RP - Remote panel		
			RPT = Remote panel with Thermostat		
A 32	Zone 2 room thermostat	Defines the temperature control in zone 2	RT = Room thermostat	RT	
			RP - Remote panel		
			RPT = Remote panel with Thermostat		
A 33	Zone 3 room thermostat	Defines the temperature control in zone 3	RT = Room thermostat	RT	
			RP - Remote panel		
			RPT = Remote panel with Thermostat		
A 41	Zone 1 heating / cooling enable	Allows to determine heating, cooling mode or both of zone 1	HT / CL / H - C	H - C	
A 42	Zone 2 heating / cooling enable	Allows to determine heating, cooling mode or both of zone 2	HT / CL / H - C	H - C	
A 43	Zone 3 heating / cooling enable	Allows to determine heating, cooling mode or both of zone 3	HT / CL / H - C	H - C	

Parameter ID	Description		Range	Default	Customised value
P00	DHW max	Defines the maximum heat output percentage of the heat generator during the D.H.W. phase compared to the maximum heat output available	0 - 100 %	100 %	
P01	Min C.H.	Defines the minimum heat output percentage of the heat generator during the C.H. phase compared to the maximum heat output available	0 - P02 %	0	
P02	Central heating max	Defines the minimum heat output percentage of the heat generator during the C.H. phase compared to the maximum heat output available	0 - 100 %	85 %	
P03	Relay 1 (optional)	The hydronic module is set up to operate with a configurable relay board (optional)	0 ÷ 5	0	
		0 = Off			
		1 = DHW recirculation			
		2 = General alarm			
		3 = Central heating / cooling mode active			
		4 = Puffer mode active			
5 = Dehumidifier zone 3					
P04	Relay 2 (optional)	The hydronic module is set up to operate with a configurable relay board (optional)	0 ÷ 5	0	
		0 = Off			
		1 = DHW recirculation			
		2 = General alarm			
		3 = Central heating / cooling mode active			
		4 = Puffer mode active			
5 = Zone 3 mixing valve closing					

INSTALLER

USER

MAINTENANCE TECHNICIAN

TECHNICAL DATA

Parameter ID	Description		Range	Default	Customised value
P05	Relay 3 (optional)	The hydronic module is set up to operate with a configurable relayboard (optional)	0 ÷ 5	0	
		0 = Off			
		1 = DHW recirculation			
		2 = General alarm			
		3 = Central heating / cooling mode active			
		4 = Puffer mode active			
P07	External probe correction	If the reading of the external probe is not accurate, it is possible to correct it in order to compensate any environmental factors	-9 ÷ 9 K	0	
P21	Activation time	Temperature setpoint - Activation time correction	0 - 120 minutes	20	
P22	Increase time	Temperature setpoint - Increment time correction	0 - 20 minutes	5	
P23	Heat setpoint correction	Allows to correct the heating mode demand setpoint in presence of dispersions or system decoupling circuits	0 ÷ 10°C	0	
P24	Cool setpoint correction	Allows to correct the cooling mode demand setpoint in presence of dispersions or system decoupling circuits	0 ÷ 10°C	0	

Parameter ID	Description		Range	Default	Customised value
T02	D.H.W. thermostat	The boiler switches off on the basis of the temperature set. Correlated: the indoor unit switches off according to the temperature set. 0 Fixed: the switch-off temperature is fixed at the maximum value regardless of the value set on the control panel.	0 ÷ 1	0	
T03	Solar delay timing	The generator is set to switch-on immediately after a request for DHW. In the case of coupling with a solar storage tank positioned upstream from the product, it is possible to compensate the distance between the storage tank and the generator in order to allow the hot water to reach the heat generator. Set the time necessary to verify that the water is hot enough (see par. Solar panels coupling)	0 - 30 seconds	0	
T04	D.H.W. priority timing	In winter mode the heat generator, at the end of a domestic hot water request, is ready to switch to central heating mode if there is an active request. Timing sets a time period in which the heat generator waits before changing the operating mode, in order to quickly and comfortably satisfy an additional request for domestic hot water	0 - 100 seconds (step 10 sec)	20	
T05	Central heating ignitions timer	The hydronic module has an electronic timer, which prevents the generator from igniting too often in central heating mode	0 - 10 minutes	3	
T06	Heating ramp timing	In the heating stage, the heat generator performs an ignition ramp in order to reach the maximum output set	0 - 14 minutes	14	

INSTALLER

USER

MAINTENANCE TECHNICIAN

TECHNICAL DATA

Parameter ID	Description		Range	Default	Customised value
T07	Delay request from TA	The system is set to switch on immediately after a request for room air conditioning. For special systems (e.g. zone systems with motorised valves, etc.), it may be necessary to delay ignition.	0 - 240 seconds (10 sec step)	0	
T08	Display lighting	Establishes the display lighting mode. AU: the display lights up during use and dims after 15 seconds of inactivity, in case of anomaly the display works in flashing mode. OFF: display lighting is always off. ON: display lighting is always on.	AU - OFF - ON	AU	
T09	Display	Establishes what the indicator displays 14 (Fig. 12). “Summer” mode: ON: active circulator, this displays the flow temperature, with circulator off the indicator is off OFF: the indicator is always off “Winter” and “cooling” mode: ON: active circulator, this displays the flow temperature, with circulator off the set value is displayed on the central heating selector OFF: this always displays the value set on the central heating selector	ON - OFF	ON	
T11	Do not use		0 ÷ 36	0	
T21	Screed heating - days at minimum temperature	Defines the time spent at minimum operating temperature during the active function	0 ÷ 7 days	3	
T22	Screed heating - ascent gradient	Defines the ascent gradient of the temperature	0 - 30°C / day	30	
T23	Screed heating - days at maximum temperature	Defines the time spent at maximum operating temperature during the active function	0 ÷ 14 days	4	
T24	Screed heating - descent gradient	Defines the descent gradient of the temperature	0 - 30°C / day	30	

Heat regulation menu.

Parameter ID	Description		Range	Default	Customised value
R01	External probe	Defines if and which external probe is used to manage the system. OFF = no external probe used OU = external probe on outdoor unit IU = optional external probe connected to the indoor unit	OFF - OU - IU	OU	
R02	Outdoor temperature for max CH flow zone 1	Establishes the outdoor temperature at which to have the maximum flow temperature of zone 1.	-15 ÷ 25°C	-5	
R03	Outdoor temperature for min CH flow zone 1	Establishes the outdoor temperature at which to have the minimum flow temperature of zone 1.	-15 ÷ 25°C	25	
R04	Zone 1 maximum central heating	Defines the maximum flow temperature in zone 1 room central heating mode	20 ÷ 80	55	
R05	Zone 1 minimum central heating	Defines the minimum flow temperature in zone 1 room central heating mode	20 ÷ 80	25	
R06	Outdoor temperature for Zone 2 low temperature zone max. CH flow	Establishes the outdoor temperature at which to have the maximum flow temperature of zone 2	-15 ÷ 25°C	-5	
R07	Outdoor temperature for Zone 2 low temperature zone min. CH flow	Establishes the outdoor temperature at which to have the minimum flow temperature of zone 2	-15 ÷ 25°C	25	
R08	Zone 2 low temperature zone maximum central heating	Defines the maximum flow temperature in zone 2 room central heating mode	20 ÷ 80	45	
R09	Zone 2 low temperature zone minimum central heating	Defines the minimum flow temperature in zone 2 room central heating mode	20 ÷ 80	25	
R10	Zone 1 outdoor temperature for minimum cooling flow	Establishes the maximum outdoor temperature at which to have the minimum flow temperature in zone 1 cooling mode	20 ÷ 40	35	
R11	Outdoor temperature for Zone 1 maximum cooling flow	Establishes the minimum outdoor temperature at which to have the maximum flow temperature in zone 1 cooling mode	20 ÷ 40	25	
R12	Zone 1 minimum cooling	Defines the minimum flow temperature in zone 1 room cooling mode	05 ÷ 20	7	
R13	Zone 1 maximum cooling	Defines the maximum flow temperature in zone 1 room cooling mode	05 ÷ 25	12	

INSTALLER

USER

MAINTENANCE TECHNICIAN

TECHNICAL DATA

Parameter ID	Description		Range	Default	Customised value
R14	Outdoor temperature for Zone 2 low temperature zone min cooling flow	Establishes the outdoor temperature at which to have the minimum flow temperature of zone 2	20 ÷ 40	35	
R15	Outdoor temperature for Zone 2 low temperature zone max cooling flow	Establishes the outdoor temperature at which to have the maximum flow temperature of zone 2	20 ÷ 40	25	
R16	Zone 2 low temperature zone minimum cooling	Defines the minimum flow temperature in zone 2 room cooling mode	05 ÷ 20	18	
R17	Zone 2 low temperature zone maximum cooling	Defines the maximum flow temperature in zone 2 room cooling mode	05 ÷ 25	20	
R21	Outdoor temperature for max CH flow zone 3	Establishes the outdoor temperature at which to have the maximum flow temperature of zone 3	-15 ÷ 25	-5	
R22	Outdoor temperature for min CH flow zone 3	Establishes the outdoor temperature at which to have the minimum flow temperature of zone 3	-15 ÷ 25	25	
R23	Zone 3 maximum central heating	Defines the maximum flow temperature in zone 3 room central heating mode	20 ÷ 80	45	
R24	Zone 3 minimum central heating	Defines the minimum flow temperature in zone 3 room central heating mode	20 ÷ 80	25	
R25	Outdoor temperature for Zone 3 low temperature zone min cooling flow	Establishes the outdoor temperature at which to have the minimum flow temperature of zone 3	20 ÷ 40	35	
R26	Outdoor temperature for Zone 3 low temperature zone max cooling flow	Establishes the outdoor temperature at which to have the maximum flow temperature of zone 3	20 ÷ 40	25	
R27	Zone 3 low temperature zone minimum cooling	Defines the minimum flow temperature in zone 3 room cooling mode	05 ÷ 20	18	
R28	Zone 3 low temperature zone maximum cooling	Defines the maximum flow temperature in zone 3 room cooling mode	05 ÷ 25	20	

Integration menu.

Parameter ID	Description		Range	Default	Customised value
I01	DHW integration enabling	Allows you to enable an alternative power source (AL) to integrate domestic hot water heating	OFF - AL	AL	
I02	System integration enabling	Using this function, you can enable an alternative (AL) power source to integrate heating system central heating	OFF - AL	AL	
I04	Central heating max wait time	Establishes the maximum amount of time before activating central heating integration	1 - 255 minutes	30	
I05	Integration activation mode	Establishes how to integrate the heat generator to the outdoor unit, you can choose between "AU" automatic and "MA" manual	AU - MA	AU	
I07	Activation band	Establishes a temperature range around the calculated temperature to determine which generator to switch on	0 ÷ 10 °C	4	
I08	Not used				
I09	DHW activation temperature	Establishes the outdoor temperature under which DHW integration is enabled	-25 ÷ 35°C	2°C	
I10	System activation temperature	Establishes the outdoor temperature under which system integration is enabled	-25 ÷ 35°C	2°C	
I11	Outdoor unit operating hours	Displays the hours of operation performed by the outdoor unit			
I12	Indoor central heating unit hours of operation	Displays the hours of operation by the indoor central heating unit			
I13	Indoor D.H.W. unit hours of operation	Displays the hours of operation by the indoor unit in DHW			

INSTALLER

USER

MAINTENANCE TECHNICIAN

TECHNICAL DATA

Maintenance menu.

Accessing this menu, the unit goes into stand-by. By selecting every single parameter, you can activate a specific function for each load.

Parameter ID	Description		Range	Default	Customised value
M02	Heat pump circuit circulator speed	Establishes the circulator speed linked to the heat pump circuit	0 - 100%	0	
M03	Heat generator 3-way circuit	Moves the 3-way motor from system to DHW	DHW-CH-MD	DHW	
M04	Cooling 3-way	Moves the cooling circuit 3-way motor	OFF - ON	OFF	
M06	Heat generator circuit circulator speed	Establishes the circulator speed linked to the heat generator	0 - 100%	0	
M07	Not used	Not used			
M08	Zone 1 outdoor circulator pump	Enables the zone 1 outdoor circulator pump	OFF - ON	OFF	
M09	Zone 2 outdoor circulator pump	Enables the zone 2 outdoor circulator pump	OFF - ON	OFF	
M10	Mixer zone 2	Establishes zone 2 mixing valve positioning	OFF - OPEN - CLOSE	OFF	
M13	Dehumidifier zone 1	Enables the dehumidifier in zone 1	OFF - ON	OFF	
M14	Dehumidifier zone 2	Enables the dehumidifier in zone 2	OFF - ON	OFF	
M15	Relay 1	Enables relay 1 on the 3-relay board	OFF - ON	OFF	
M16	Relay 2	Enables relay 2 on the 3-relay board	OFF - ON	OFF	
M17	Relay 3	Enables relay 3 on the 3-relay board	OFF - ON	OFF	
M18	Zone 3 outdoor circulator pump	Enables the zone 3 outdoor circulator	OFF - ON	OFF	
M19	Dehumidifier zone 3	Enables the dehumidifier in zone 3	OFF - ON	OFF	
M20	Zone 3 mixing valve	Establishes zone 3 mixing valve positioning	OFF - OPEN - CLOSE	OFF	

3.13 "CHIMNEY SWEEP" FUNCTION

If activated, this function makes the indoor unit work at an adjustable power. In this state all adjustments are excluded and only the safety thermostat and the limit thermostat remain active.

This function can only be activated without any requests.

To activate the chimney sweep function, select the "Winter" mode, in the absence of DHW and central heating requests, and press the "Reset" button for 8 seconds. Its activation is signalled by the relative symbol (17-18 flashing, Fig. 42)

Once activated, the chimney sweep function in central heating mode must be enabled from a zone room thermostat.

For the chimney sweep function in DHW mode, after activation, open a tap and draw some domestic water.

During operation it is possible to edit system and DHW setpoints.

This function allows the technician to check the combustion parameters.

On completion of the checks, deactivate the function by pressing the "Reset" button for 1 second.

3.14 PUMP ANTI-BLOCK FUNCTION

The indoor unit has a function that starts the pump at least once every 24 hours for the duration of 30 seconds in order to reduce the risk of the pump becoming blocked due to prolonged inactivity.

3.15 THREE-WAY ANTI-BLOCK SYSTEM

The indoor unit has a function that activates the motorised three-way unit 24 hours after the last time it operated by running a complete cycle in order to reduce the risk of the three-way blocking due to prolonged inactivity.

3.16 RADIATORS ANTIFREEZE FUNCTION

If the system water is close to freezing, the appliance starts up until it reaches a safety temperature.

3.17 PHOTOVOLTAICFUNCTION

Should the photovoltaic contact (contact “S 39” Fig. 8) be closed, the minimum outdoor temperature is temporarily set at -15°C.

3.18 OUTDOORUNIT DISABLEFUNCTION

With input active (contact “S 41” Fig. 8) operation of the outdoor unit is inhibited.
The demands can only be satisfied by the heat generator.

3.19 PREHEATINGFUNCTION

In case of DHW or heating demand, if the water temperature is lower than 20 °C, the operation of the integration electric resistance is forced until 25 °C are reached.

3.20 DIVERTER VALVE MANAGEMENT (SUMMER / WINTER).

The unit electronics has a 230V outlet to manage the summer / winter diverter valves.
The voltage output is active when the appliance is in Air-conditioning mode.

3.21 AUTOMATIC VENTING FUNCTION

In the case of new central heating systems and in particular mode for floor systems, it is very important that deaeration is performed correctly.

The function consists of the cyclic activation of the pump and the 3-way valve.

The function is activated in two different ways:

- Each time the heat generator is re-powered;
- Using parameter “U 50”.

In the first case, the function has a duration of 8 minutes and it can be interrupted by pressing the “Reset” button (3). In the second case, it has a duration of 18 hours and it can be interrupted simply by switching the heat generator on.

Activation of the function is signalled by the countdown shown on the indicator (14).

3.22 SCREED HEATER FUNCTION

The indoor unit is equipped with a function to perform the thermal shock on new radiant panel systems, as required by the applicable standard.



Contact the manufacturer of the radiant panels for the thermal shock characteristics and its correct execution.



To be able to activate the function there must be no remote control connected, while in case of system divided into zones it must be properly connected, both hydraulically and electrically.



The active zone pumps are those with ongoing requests, made via the room thermostat input.

The function is activated from indoor unit in stand-by by pressing and holding the buttons “Reset” and “Mode” for more than 5 seconds (Fig. 61).

The standard function lasts in total 7 days - 3 days at the lowest temperature set and 4 days at the highest temperature set (Fig. 8).

Duration can be changed by changing the value of parameters "T 22" and "T24".

After activating the function, the lower set (range 20 ÷ 45 °C default = 25 °C) and the higher set (range 25 ÷ 55 °C default = 45 °C) appear in sequence.

The temperature is selected by means of the buttons “+” and “-” of the system side ( ) and confirmed by pressing the button “Mode”.

The display now shows the countdown of days alternated with the current flow temperature, as well as the normal operating symbols of the indoor unit.

In case of failure, the function is suspended and will resume when normal operating conditions are reset from the point where it was interrupted.

In case of power failure, the function is suspended.

When the time expires, the indoor unit automatically goes back to “Stand-by” mode, the function can also be stopped by pressing the button “Mode”.

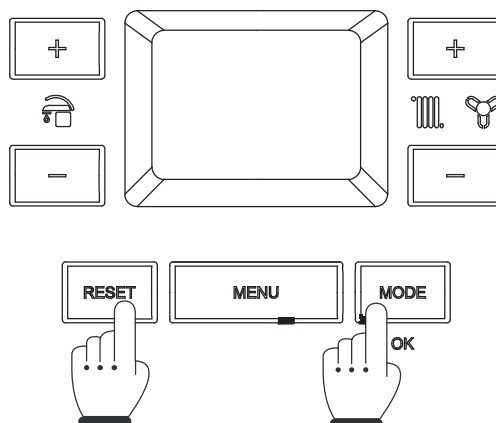

3.23 SOLAR PANELS COUPLING FUNCTION

The indoor unit is prepared to receive pre-heated water from a system of solar panels up to a maximum temperature of 65°C. In any case, it is always necessary to install a mixing valve on the hydraulic circuit upstream of the indoor unit, on the cold water inlet.

To optimise the operation, the solar inlet probe kit is available on request (see wiring diagram Fig. 8).

To enable the use of the probe it is necessary to set parameter T03>0.

This kit allows you to connect a probe on the domestic cold water inlet pipe of the indoor unit, to prevent unnecessary start-ups in systems with water heating through solar systems or alternative sources.

The indoor unit will not turn on if the inlet water is sufficiently hot.

We recommend setting parameter T03 (solar delay timer) at a time sufficient to let the water inside the D.H.W. circuit upstream of the indoor unit drain.

The greater the distance from the storage tank, the longer wait time will have to be set.

With these adjustments made, when a domestic withdrawal is requested, once the time set on parameter “T03” has passed, if the water entering the indoor unit is at a temperature that is equal to or greater than that set, the indoor unit will not turn on.



In order for the indoor unit to work properly, the temperature selected on the mixing valve must be 5°C higher than the temperature selected on the indoor unit control panel.

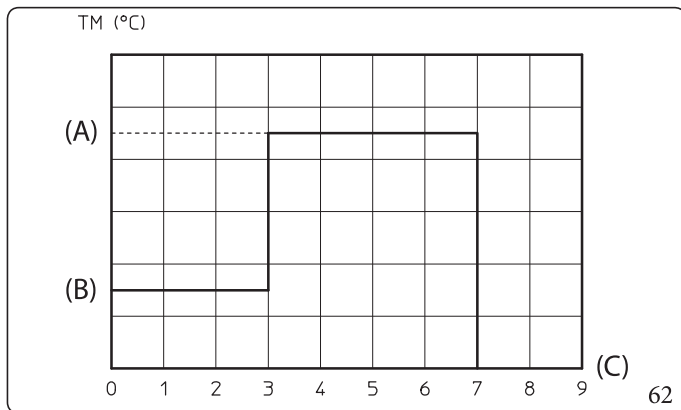

Key (Fig. 62):

(A) - Topset

(B) - Lowerset

(C) - Days

TM - Flow temperature

3.24 DEHUMIDIFICATION FUNCTION

Dehumidification can be performed according to two different types of devices:

- 1) Humidistat;
- 2) Humidity sensor.

In the first case, the cooling mode temperature corresponds to:

- In the event of dehumidification request: maximum setpoint set for the request zone;
- In the event of dehumidification and cooling request: setpoint set for the request zone.

In the second case, the cooling mode temperature corresponds to:

- In the event of dehumidification request: maximum setpoint set for the request zone;
- In the event of dehumidification request and cooling request: setpoint set for the request zone, but limited by the calculated dew temperature.



The dew temperature is only calculated for adjustments above or equal to 15°C.

3.25 OUTDOOR UNIT TEST MODE FUNCTION

When test mode is used (see outdoor unit instruction booklet), the indoor unit must be set in a mode other than “Stand-by”.

The alarm E183 is triggered during the test, meaning “Test mode” in progress.

3.26 OUTDOOR UNIT PUMP DOWN FUNCTION

If the pump down function is used (see outdoor unit instruction booklet) the indoor unit must be set in "Stand-by".
The function can only be activated if the appliance is not under alarm.

3.27 PUFFER IN PREHEATING FUNCTION

In the presence of an inertial storage tank heated by other sources of heat, following a central heating demand, it is possible to prevent the generators from being activated by using hot water coming from the puffer

The function is activated by setting one of the relays of the relay board at 4. (see P03, P04, P05).

The puffer function requires the puffer probe.

See the instruction sheet of the relay board for details and examples

3.28 NIGHT MODE FUNCTION

This function can be activated by setting the internal clock of the appliance (parameters U 21 and U 22).

Activating the function allows you to reduce the compressor frequency during the outdoor unit operation in the time slot set in the U 12 and U 13 parameters.

3.29 SYSTEM SETPOINT CORRECTION FUNCTION

In the presence of hydraulic disconnections on the system which separate the appliance from the low temperature zone (zone 2), a function can be activated which allows to meet the demands, by correcting the appliance's setpoint.

The corrections can be made either in heating or cooling mode only.

They are activated by setting the parameters P 23 or P 24 at a value $> 0^{\circ}\text{C}$.

Following a demand, the correction begins after a time equal to P 21 and continues by 1°C every P 22 minutes.

3.30 GENERATOR MANAGEMENT

Central heating mode

Following a request in room heating mode, the electronic system decides, depending on the external temperature and set point configured, whether to activate heat pump mode, or (with "freezing" external temperatures) the heat generator (Fig. 63).

The management electronics select which heat source to be used according to the combination of "I" family parameters. The heat generator could also switch on also when external conditions are favourable; this can take place after a time proportional to the parameter.

Alternatively, you can also set a fixed switching outdoor temperature (manual mode in the parameter "I05" setting the temperature with "I06"). The D.H.W. demand is met by the heat generator, even simultaneously with a system demand which is met by the heat pump mode.



To protect the appliance the heat pump might start up even if the appliance is in the heat generator exclusive operating zone.

Operation in central heating mode

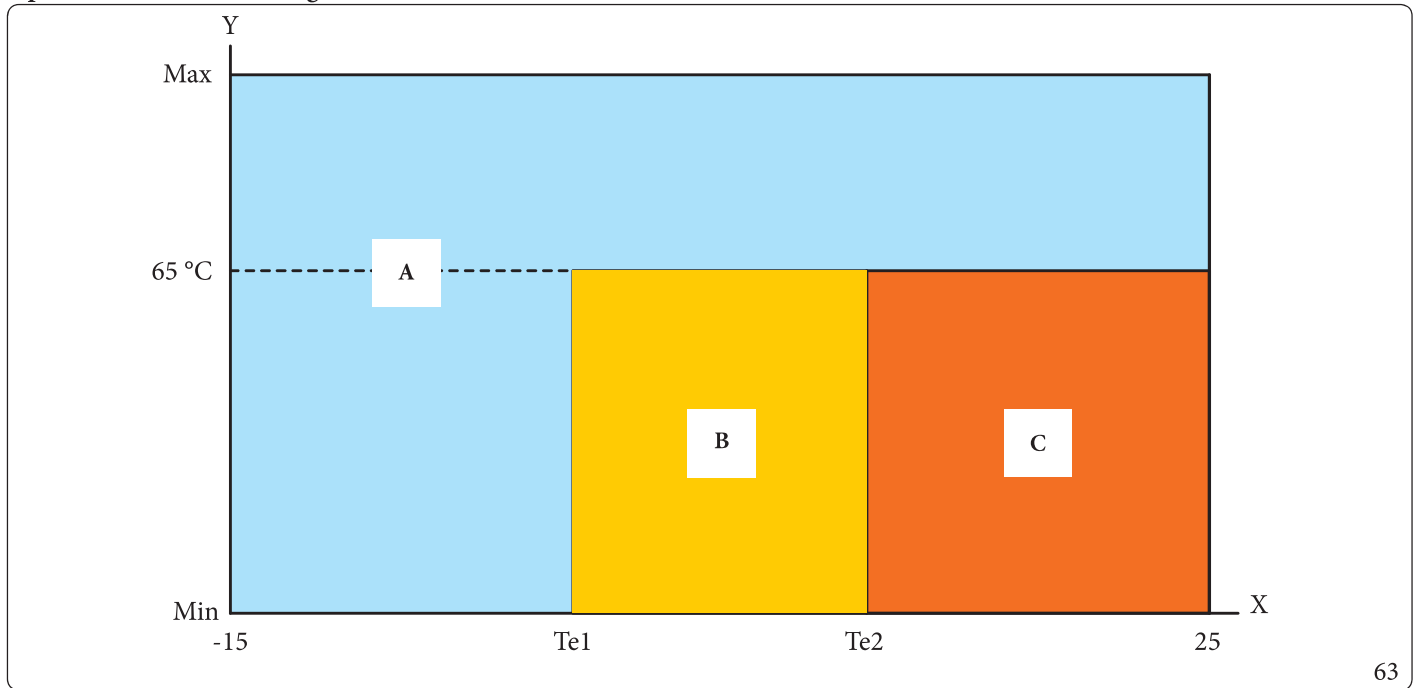

Key (Fig. 63):

- X - Outside temperature
- Y - Central heating/C.H. set
- A - Exclusive heat generator operation
- B - Heat pump operation (if after activation time the set temperature is not reached **the heat generator starts**)*
- C - Heat pump operation (if after activation time multiplied by 2 the set temperature is not reached **the heat generator starts**)*

The Te1 and Te2 values are determined by the logic of the product board (Setting manual mode "I05" = "MA" the value of "Te1" is the same as "I06" and the value of "Te2" is the same as "I06" + 5 °C).
 * = The heat pump will then restart, thereby creating an alternating mechanism between the two generators.

INSTALLER

USER

MAINTENANCE/TECHNICIAN

TECHNICAL DATA

3.31 CASING REMOVAL

To facilitate indoor unit maintenance the casing can be completely removed as follows:

Lower grid (Fig. 64)

- Loosen the two screws (a).
- Press the hooks inwards, which block the lower grid (b).
- Remove the grid (b).

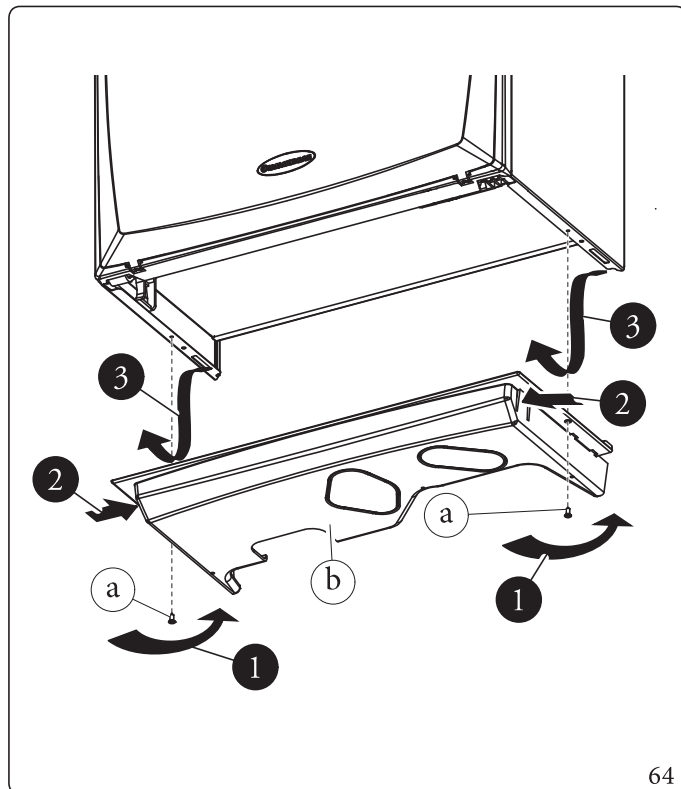

64

Front panel (Fig. 65)

- Open the protection door (e1) pulling it towards you.
- Remove the cover caps (c) and loosen screws (d).
- Pull the front panel (e) towards you and release it from its lower seat.

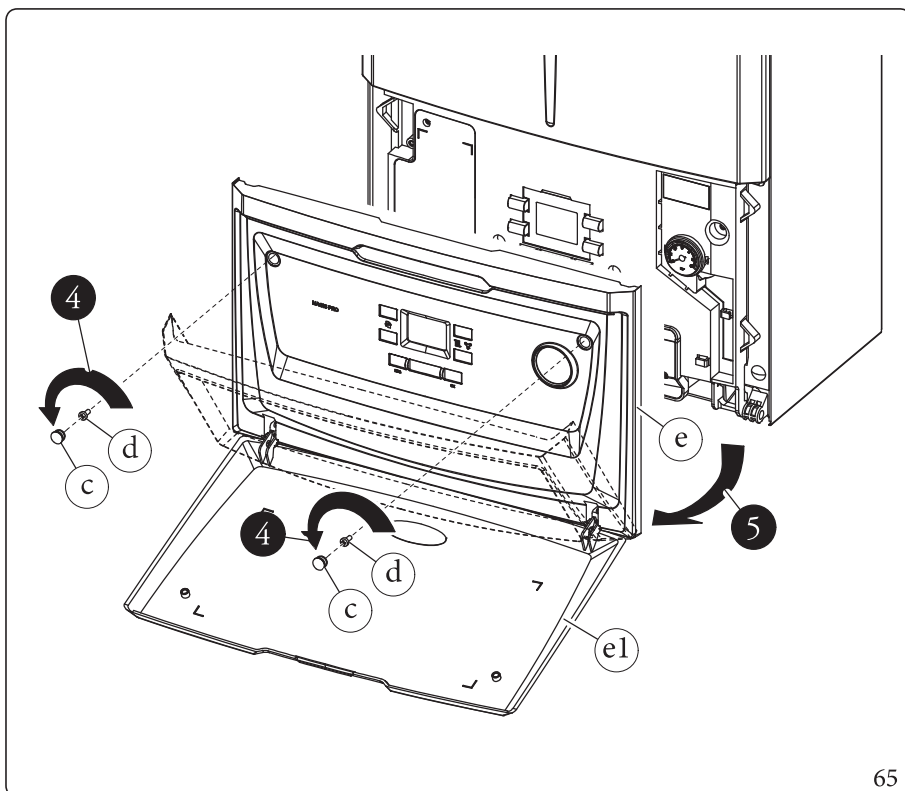

65

Front (Fig. 66)

- Loosen the two screws (g).
- Pull the front (f) slightly towards you.
- Release front (f) from pins (h) pulling it towards you while pushing it upwards at the same time.

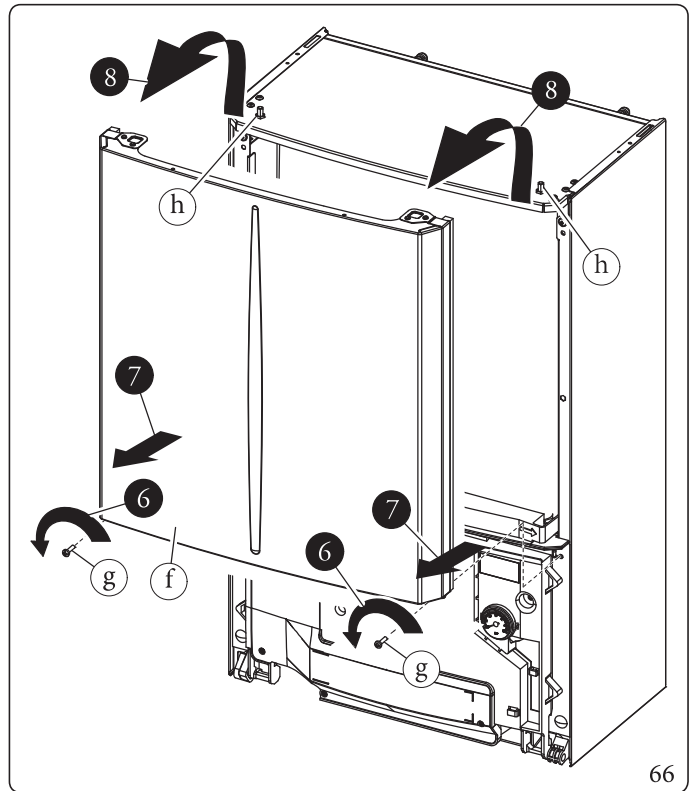

INSTALLER

USER

Control panel (Fig. 68)

- Press the hooks on the side of the control panel (i).
 - Tilt the control panel (i) towards you.
- The control panel (i) can rotate until the support cord (j) is completely extended.
- If the left side needs to be removed, unhook the support cord (j) from the control panel and proceed as follows.

INTERFACE BOARD

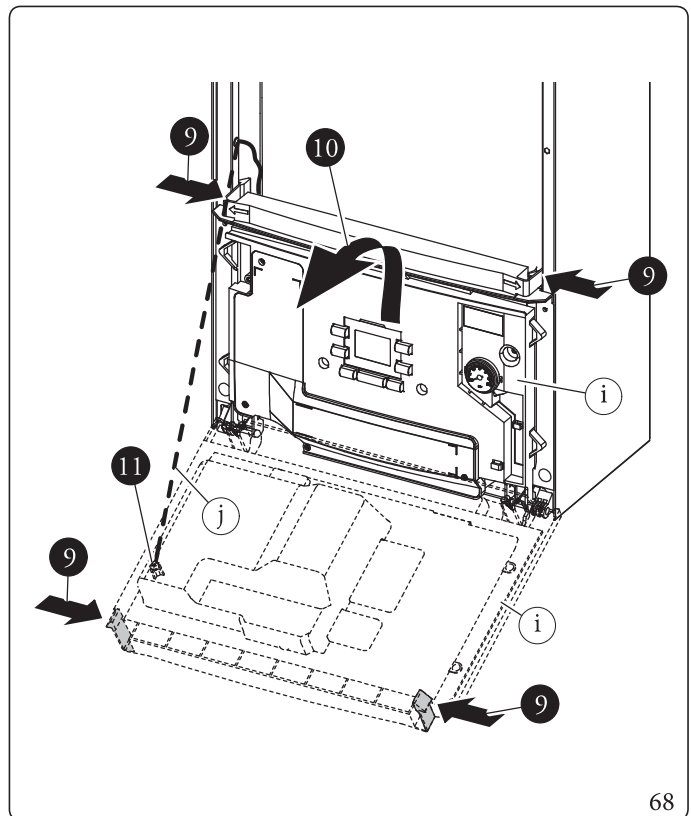
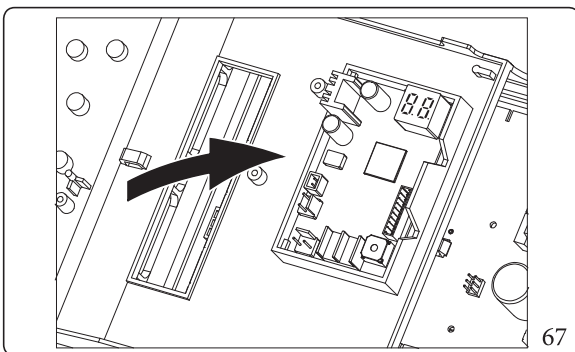

MAINTENANCE/TECHNICIAN

TECHNICAL DATA

Sides (Fig. 69)

- Unscrew the side (k) fastening screws (l).
- Remove the sides by extracting them from their rear seat (Ref. X).

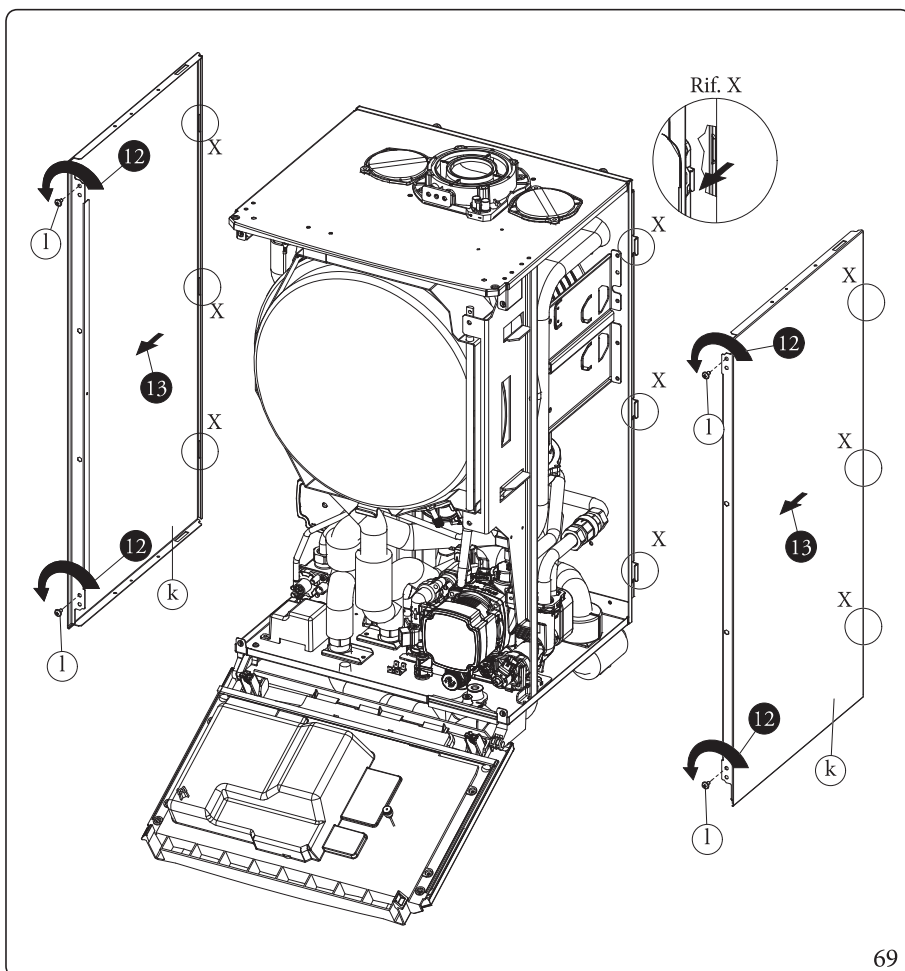

4 TECHNICAL DATA

4.1 VARIABLE HEAT OUTPUT

Indoor unit data



The power data in the table has been obtained with intake-exhaust pipe measuring 0.5 m in length. Gas flow rates refer to net calorific value below a temperature of 15°C and at a pressure of 1013 mbar.

MAX DHW HEAT INPUT kW 28.1				
GAS	FAN SPEED VARIATION INTERVAL		ΔP VENTURI	
	(rpm)		(rpm)	(mm c.a.)
METHANE (G20)	5100 - 5400		6,62	67,5
BUTANE (G30)	4800 - 5100		6,32	64,5
PROPANE (G31)	5400 - 5600		8,01	81,7

HEAT OUTPUT	HEAT OUTPUT		METHANE (G20)		BUTANE (G30)		PROPANE (G31)	
			MODULATION	GAS FLOW RATE BURNER	MODULATION	GAS FLOW RATE BURNER	MODULATION	GAS FLOW RATE BURNER
(kW)	(kcal/h)		(%)	(m ³ /h)	(%)	(kg/h)	(%)	(kg/h)
27,3	23478	D.H.W.	99	2,98	99	2.22	99	2,19
27,0	23220		98	2,95	98	2.20	98	2,16
26,0	22360		94	2,85	94	2.13	94	2,09
25,0	21500		90	2,74	90	2.05	90	2,01
24,0	20640		85	2,64	85	1.97	85	1,94
23,0	19780	HEAT. + D.H.W.	81	2,53	81	1.89	81	1,86
22,0	18926		75	2,42	75	1.81	75	1,78
21,0	18060		70	2,31	70	1.73	70	1,70
20,0	17200		64	2,20	64	1.64	64	1,62
19,0	16340		59	2,09	59	1.56	59	1,53
18,0	15480		53	1,98	53	1.48	53	1,45
17,0	14620		48	1,87	48	1.39	48	1,37
16,0	13760		43	1,76	43	1.31	43	1,29
15,0	12900		38	1,65	38	1.23	38	1,21
14,0	12040		34	1,54	34	1.15	34	1,13
13,0	11180		29	1,43	29	1.07	29	1,05
12,0	10320		25	1,32	25	0.99	25	0,97
11,0	9460		22	1,22	22	0.91	22	0,89
10,0	8600		18	1,11	18	0.83	18	0,81
9,0	7740		15	1,00	15	0.75	15	0,73
8,0	6880		11	0,89	11	0.66	11	0,65
7,0	6020		8	0,78	8	0.58	8	0,57
6,0	5160	4	0,67	4	0.50	4	0,49	
5,0	4300	1	0,56	1	0.42	1	0,41	
4.8	4128	1	0,54	1	0.40	1	0,40	

INSTALLER

USER

MAINTENANCE TECHNICIAN

TECHNICAL DATA

System data (Indoor unit + outdoor unit)

		MAGISCOMBO 4 V2	MAGISCOMBO 6 V2	MAGISCOMBO 9 V2
Nominal data for low temperature applications (A7/W35)*				
Nominal central heating output	kW	4,40	6,00	9,00
Absorption	kW	0,85	1,22	1,87
COP	kW/kW	5,20	4,92	4,81
Nominal data for low temperature applications (A35/W18)*				
Nominal cooling output	kW	5,00	6,50	8,70
Absorption	kW	1,09	1,47	2,11
EER	kW/kW	4,59	4,42	4,12
Nominal data for intermediate temperature applications (A7/W45)**				
Nominal central heating output	kW	4,20	5,40	8,60
Absorption	kW	1,03	1,51	2,33
COP	kW/kW	4,08	3,58	3,69
Nominal data for intermediate temperature applications (A35/W7)**				
Nominal cooling output	kW	3,60	4,70	6,50
Absorption	kW	1,11	1,44	1,95
EER	kW/kW	3,24	3,26	3,33
Nominal data for medium temperature applications (A7/W55)***				
Nominal central heating output	kW	3,90	4,80	8,00
Absorption	kW	1,32	1,81	2,73
COP	kW/kW	2,95	2,65	2,93

* Central heating mode status: heat exchanger water inlet/remains at 30°C/35°C, outdoor air temperature 7°C db/6°C wb. Performance in compliance with EN 14511.

Cooling mode status: heat exchanger water inlet/remains at 23°C/18°C, outdoor air temperature 35°C. Performance in compliance with EN 14511.

* Central heating mode status: heat exchanger water inlet/remains at 40°C/45°C, outdoor air temperature 7°C db/6°C wb.

Cooling mode status: heat exchanger water inlet/remains at 12°C/7°C, outdoor air temperature 35°C. Performance in compliance with EN 14511.

*** Central heating mode status: inlet/remains at 47°C/55°C, outdoor air temperature 7°C db/6°C wb. Performance in compliance with EN 14511.

4.2 COMBUSTION PARAMETERS

Indoor unit data

Gas type		G20	G30	G31
Supply pressure	mbar (mm H ₂ O)	20 (204)	29 (296)	31 (377)
Gas nozzle diameter	mm	5.6	3.9	4.1
Flue flow rate at D.H.W. nominal heat output	kg/h (g/s)	44 (12.17)	40 (11.04)	45 (12.51)
Flue flow rate at heating nominal heat output	kg/h (g/s)	38 (10.69)	35 (9.79)	40 (11)
Flue flow rate at min heat output	kg/h (g/s)	9 (2.43)	8 (2.17)	9 (2.39)
CO ₂ to nominal Q.	%	9.6 (±0,2)	12.3 (-)	10.6 (±0,2)
CO ₂ to ignition Q.	%	8.6 (±0,2)	11.2 (-)	10 (±0,2)
CO ₂ to minimum Q.	%	8.6 (±0,2)	11.2 (-)	10 (±0,2)
CO with 0% O ₂ at Nom./Min. Q.	ppm	250 / 7	697 / 10	222 / 6
NO _x with 0% O ₂ at Nom./Min. Q.	mg/kWh	52 / 17	137 / 38	40 / 21
Flue temperature at nominal output	°C	70	76	70
Flue temperature at minimum output	°C	57	67	62
Max air combustion temperature	°C	50	-	50

INSTALLER

USER

MAINTENANCE TECHNICIAN

TECHNICAL DATA

4.3 TECHNICAL DATA TABLE

Indoor unit data

		MAGISCOMBO V2 Indoor Unit
Domestic hot water nominal heat input	kW (kcal/h)	28.1 (24204)
Central heating nominal heat input	kW (kcal/h)	24.9 (21455)
Minimum heat input	kW (kcal/h)	5.1 (4382)
Domestic hot water nominal heat output (useful)	kW (kcal/h)	27.3 (23478)
Central heating nominal heat output (useful)	kW (kcal/h)	24 (20640)
Minimum heat output (useful)	kW (kcal/h)	4.8 (4128)
*Effective thermal efficiency 80/60 Nom./Min.	%	96.2/94.2
*Effective thermal efficiency 50/30 Nom./Min.	%	-/-
*Effective thermal efficiency 40/30 Nom./Min.	%	-/-
Casing losses with burner On/Off (80-60°C)	%	0,45/0,20
Chimney losses with burner On/Off (80-60°C)	%	0,01/2,80
Central heating circuit max. operating pressure	bar (MPa)	3,0 (0,30)
Maximum heating temperature	°C	83
Adjustable central heating temperature (min. operating field)	°C	20
Adjustable central heating temperature (max operating field)	°C	80
System expansion vessel total volume	l	8.3
Expansion vessel pre-charged pressure	bar (MPa)	1,0 (0,10)
Appliance water content	l	2.8
Head available with 1000l/h flow rate	kPa (mH ₂ O)	4.9 mca (48.29 KPa)
Hot water production useful heat output	kW (kcal/h)	27.3 (23478)
Domestic hot water adjustable temperature	°C	10-65
Domestic hot water circuit min. pressure (dynamic)	bar (MPa)	0,3 (0,03)
Domestic hot water circuit max. operating pressure	bar (MPa)	10,0 (1,00)
Flow rate capacity in continuous duty (ΔT 30°C)	l/min	13.1
Weight of full boiler	kg	58.6
Weight of empty boiler	kg	55.8
Electrical connection	V/Hz	230/50
Nominal power absorption	A	1.2
Installed electric power	W	160
Pump absorbed power	W	60
EEl value	-	≤0.20 - Det. 3
Fan power absorbed power	W	80
Equipment electrical system protection	-	IPX4 D
Max temperature of combustion products	°C	75
Max. flue overheating temperature	°C	120
Ambient operating temperature range	°C	-5 ÷ +50
Ambient operating temperature range with optional antifreeze kit	°C	-15 ÷ +50
NO _x class	-	6
Weighted NO _x	mg/kWh	29
Weighted CO	mg/kWh	20
**Type of appliance	-	C13-C13x-C33-C33x-C43-C43x-C53-C53x-C63-C63x-C83-C83x-C93-C93x B23-B33-B53

** For type C63 it is forbidden to install the appliance as it came out of the factory, in configurations that require shared flues in positive pressure.

Outdoor unit - Ambient operating temperature range.

		MAGIS COMBO 4 V2	MAGIS COMBO 6 V2	MAGIS COMBO 9 V2
Room temperature in cooling mode	°C		+10..+46	
Room temperature in central heating mode	°C		-25..+35	
Domestic hot water room temperature	°C		-25..+46	
Domestic hot water room temperature with DHW integration resistance (optional)	°C		-	

4.4 MAGIS COMBO 4 V2 PRODUCT FICHE (IN COMPLIANCE WITH REGULATION 811/2013)

For proper installation of the appliance refer to chapter 1 of this booklet (for the installer) and current installation regulations. For proper maintenance refer to chapter 3 of this booklet (for the maintenance technician) and adhere to the frequencies and methods set out herein.

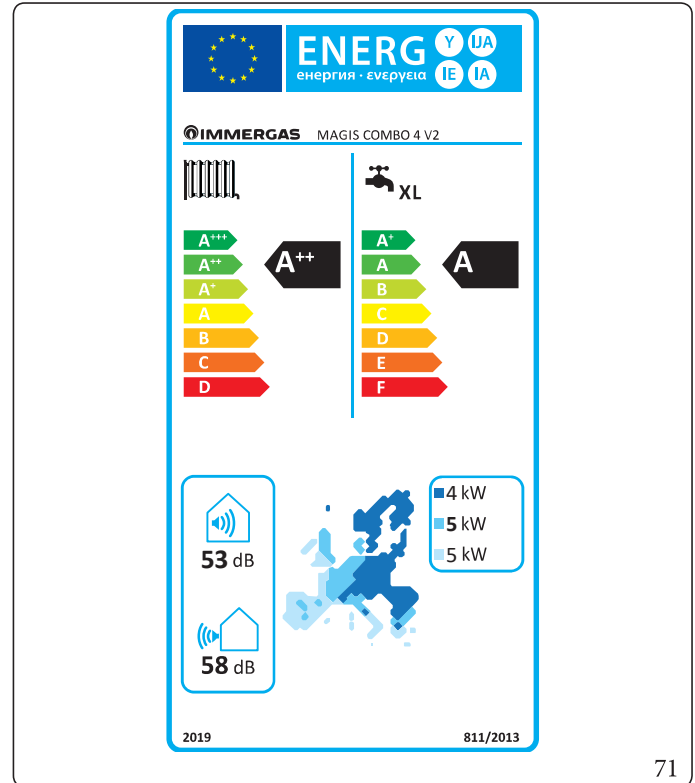
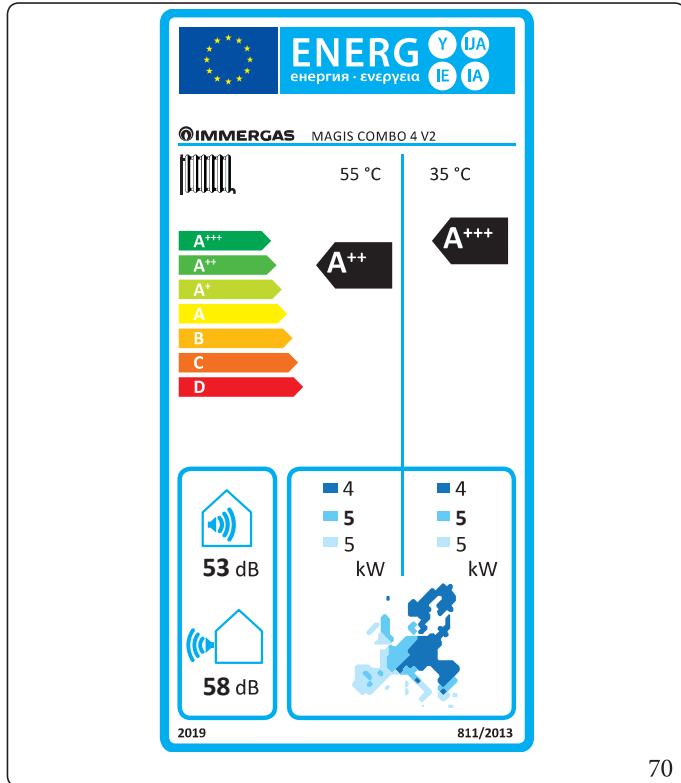

Low temperature (30/35)

Parameter	Value	Colder zones	Average zones	Hotter zones
Annual energy consumption for the central heating mode (Q_{HP})	kWh/year	2768	2243	1125
Room central heating seasonal efficiency (η_s)	η_s %	140	181	235
Nominal heat output	kW	4,00	5,00	5,00

Average temperature (47/55)

Parameter	Value	Colder zones	Average zones	Hotter zones
Annual energy consumption for the central heating mode (Q_{HP})	kWh/year	3982	3163	1753
Room central heating seasonal efficiency (η_s)	η_s %	96	128	150
Nominal heat output	kW	4,00	5,00	5,00

INSTALLER

USER

MAINTENANCE TECHNICIAN

TECHNICAL DATA

Average temperature table (47/55) average zones

Model	MAGIS COMBO 4V2						
Air/water heat pump	yes	Low temperature heat pump				no	
Water/water heat pump	no	With additional central heating device				yes	
Brine/water heat pump	no	Mixed central heating device with heat pump:				yes	
The parameters are declared for average temperature application, except for low temperature heat pumps. The parameters for low temperature heat pumps are declared for low temperature application							
The parameters are declared for average climatic conditions							
Element	Symbol	Value	Unit	Element	Symbol	Value	Unit
Nominal heat output	$P_{nomi-nale}$	5,00	kW	Room central heating seasonal energy efficiency	η_s	128	%
Central heating capacity declared with a partial load and indoor temperature equivalent to 20°C and outdoor temperature T_j				Performance coefficient declared with indoor temperature equivalent to 20°C and outdoor temperature T_j			
$T_j = -7^\circ\text{C}$	Pdh	4,4	kW	$T_j = -7^\circ\text{C}$	COPd	2,10	-
$T_j = +2^\circ\text{C}$	Pdh	2,7	kW	$T_j = +2^\circ\text{C}$	COPd	3,10	-
$T_j = +7^\circ\text{C}$	Pdh	1,7	kW	$T_j = +7^\circ\text{C}$	COPd	4,46	-
$T_j = +12^\circ\text{C}$	Pdh	1,9	kW	$T_j = +12^\circ\text{C}$	COPd	5,72	-
$T_j = \text{bivalent temperature}$	Pdh	4,4	kW	$T_j = \text{bivalent temperature}$	COPd	2,10	-
$T_j = \text{operating limit temperature}$	Pdh	4,2	kW	$T_j = \text{operating limit temperature}$	COPd	1,51	-
for air/water heat pumps: $T_j = -15^\circ\text{C}$ (se TOL < -20°C)	Pdh	0,0	kW	for air/water heat pumps: $T_j = -15^\circ\text{C}$ (se TOL < -20°C)	COPd	0	-
Bivalent temperature	T_{biv}	-7	°C	for air/water heat pumps: Operating limit temperature	TOL	-10	°C
Central heating capacity cycle intervals	Ppsych	0,0	kW	Cycle intervals efficiency	COPd	0	-
Degradation coefficient	Cdh	0,9	-	Water heating temperature operating limit	WTOL	0	°C
Different mode of energy consumption from the active mode				Additional heating appliance			
OFF mode	P_{OFF}	0,000	kW	Nominal heat output	P_{sup}	24,00	kW
Thermostat mode off	P_{TO}	0,010	kW	Type of energy supply voltage	FOSSIL FUEL		
Standby mode	P_{SB}	0,010	kW				
Guard heating mode	P_{CK}	0,000	kW				
Other items							
Capacity control	VARIABLE			For air/water heat pumps: nominal air output to outside	-	2400	m ³ /h
Indoor/outdoor sound level	L_{WA}	58	dB	For water or brine/water heat pumps: nominal flow of brine or water, outdoor heat exchanger	-	-	m ³ /h
Annual energy consumption	Q_{HE}	3163	kWh or GJ				
For mixed central heating appliances with a heat pump							
Stated load profile	XL			Water central heating energy efficiency	η_{wh}	86	%
Daily electrical power consumption	Q_{elec}	0,305	kWh	Daily fuel consumption	Q_{fuel}	22,14	kWh
Annual energy consumption	AEC	67	kWh	Annual fuel consumption	AFC	17	GJ
Contact information	Immergas S.p.A. via Cisa Ligure n.95						

4.5 MAGIS COMBO 6 V2 PRODUCT FICHE (IN COMPLIANCE WITH REGULATION 811/2013)

For proper installation of the appliance refer to chapter 1 of this booklet (for the installer) and current installation regulations.
For proper maintenance refer to chapter 3 of this booklet (for the maintenance technician) and adhere to the frequencies and methods set out herein.

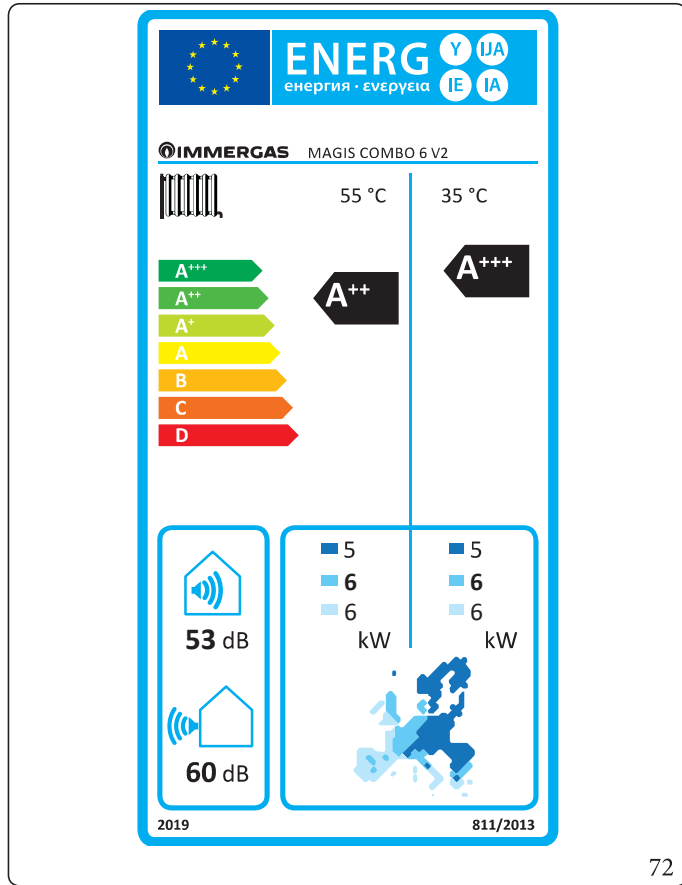

72

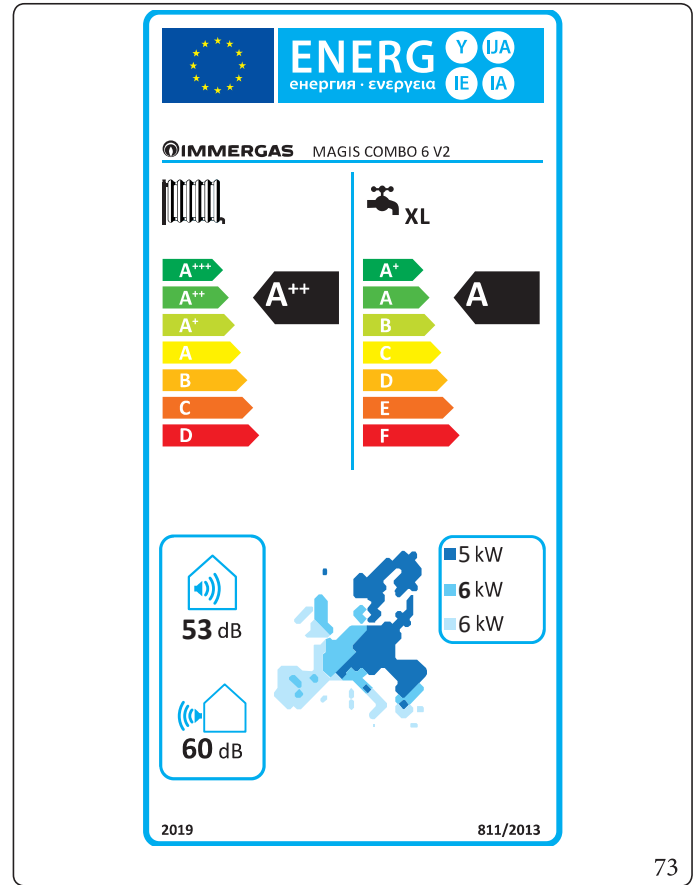

73

Low temperature (30/35)

Parameter	Value	Colder zones	Average zones	Hotter zones
Annual energy consumption for the central heating mode (Q_{HF})	kWh/year	3305	2692	1254
Room central heating seasonal efficiency (η_s)	η_s %	140	181	236
Nominal heat output	kW	4,80	6,00	5,60

Average temperature (47/55)

Parameter	Value	Colder zones	Average zones	Hotter zones
Annual energy consumption for the central heating mode (Q_{HF})	kWh/year	4941	3727	1945
Room central heating seasonal efficiency (η_s)	η_s %	93	130	151
Nominal heat output	kW	4,80	6,00	5,60

INSTALLER

USER

MAINTENANCE TECHNICIAN

TECHNICAL DATA

Average temperature table (47/55) average zones

Model		MAGIS COMBO 6V2					
Air/water heat pump	yes	Low temperature heat pump			no		
Water/water heat pump	no	With additional central heating device			yes		
Brine/water heat pump	no	Mixed central heating device with heat pump:			yes		
The parameters are declared for average temperature application, except for low temperature heat pumps. The parameters for low temperature heat pumps are declared for low temperature application							
The parameters are declared for average climatic conditions							
Element	Symbol	Value	Unit	Element	Symbol	Value	Unit
Nominal heat output	$P_{nomi-nale}$	6,00	kW	Room central heating seasonal energy efficiency	η_s	130	%
Central heating capacity declared with a partial load and indoor temperature equivalent to 20°C and outdoor temperature T_j				Performance coefficient declared with indoor temperature equivalent to 20°C and outdoor temperature T_j			
$T_j = -7^\circ\text{C}$	Pdh	5,3	kW	$T_j = -7^\circ\text{C}$	COPd	2,00	-
$T_j = +2^\circ\text{C}$	Pdh	3,2	kW	$T_j = +2^\circ\text{C}$	COPd	3,23	-
$T_j = +7^\circ\text{C}$	Pdh	2,1	kW	$T_j = +7^\circ\text{C}$	COPd	4,47	-
$T_j = +12^\circ\text{C}$	Pdh	1,9	kW	$T_j = +12^\circ\text{C}$	COPd	5,82	-
$T_j =$ bivalent temperature	Pdh	5,3	kW	$T_j =$ bivalent temperature	COPd	2,00	-
$T_j =$ operating limit temperature	Pdh	5,0	kW	$T_j =$ operating limit temperature	COPd	1,80	-
for air/water heat pumps: $T_j = -15^\circ\text{C}$ (se TOL < -20°C)	Pdh	0,0	kW	for air/water heat pumps: $T_j = -15^\circ\text{C}$ (se TOL < -20°C)	COPd	0	-
Bivalent temperature	T_{biv}	-7	°C	for air/water heat pumps: Operating limit temperature	TOL	-10	°C
Central heating capacity cycle intervals	Ppsych	0,0	kW	Cycle intervals efficiency	COPd	0	-
Degradation coefficient	Cdh	0,9	-	Water heating temperature operating limit	WTOL	0	°C
Different mode of energy consumption from the active mode				Additional heating appliance			
OFF mode	P_{OFF}	0,000	kW	Nominal heat output	P_{sup}	24,00	kW
Thermostat mode off	P_{TO}	0,010	kW	Type of energy supply voltage	FOSSIL FUEL		
Standby mode	P_{SB}	0,010	kW				
Guard heating mode	P_{CK}	0,000	kW				
Other items							
Capacity control	VARIABLE			For air/water heat pumps: nominal air output to outside	-	2580	m ³ /h
Indoor/outdoor sound level	L_{WA}	60	dB	For water or brine/water heat pumps: nominal flow of brine or water, outdoor heat exchanger	-	-	m ³ /h
Annual energy consumption	Q_{HE}	3727	kWh or GJ				
For mixed central heating appliances with a heat pump							
Stated load profile	XL			Water central heating energy efficiency	η_{wh}	86	%
Daily electrical power consumption	Q_{elec}	0,305	kWh	Daily fuel consumption	Q_{fuel}	22,14	kWh
Annual energy consumption	AEC	67	kWh	Annual fuel consumption	AFC	17	GJ
Contact information	Immergas S.p.A. via Cisa Ligure n.95						

4.6 MAGIS COMBO 9 V2 PRODUCT FICHE (IN COMPLIANCE WITH REGULATION 811/2013)

For proper installation of the appliance refer to chapter 1 of this booklet (for the installer) and current installation regulations.
For proper maintenance refer to chapter 3 of this booklet (for the maintenance technician) and adhere to the frequencies and methods set out herein.

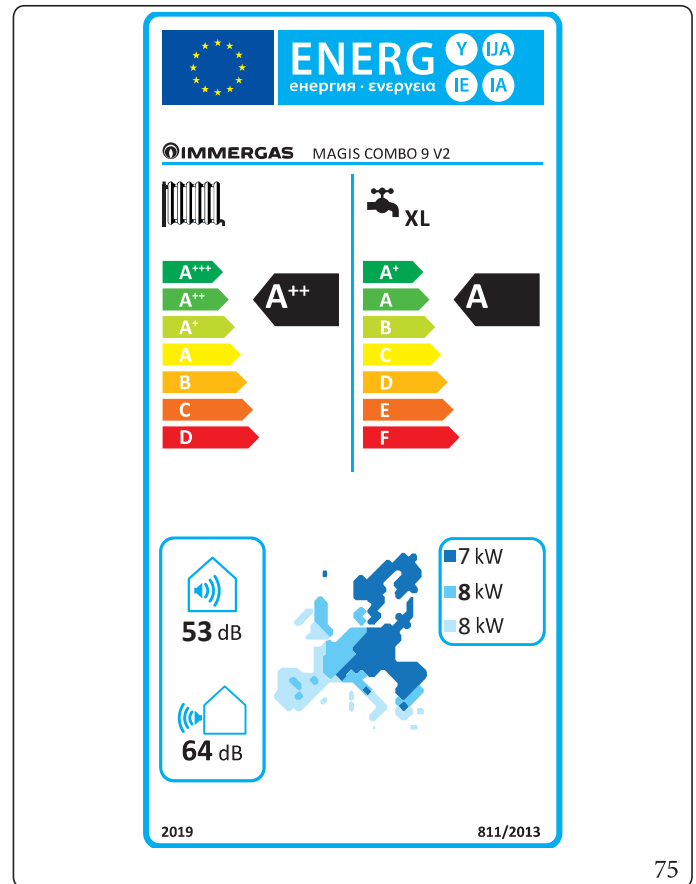
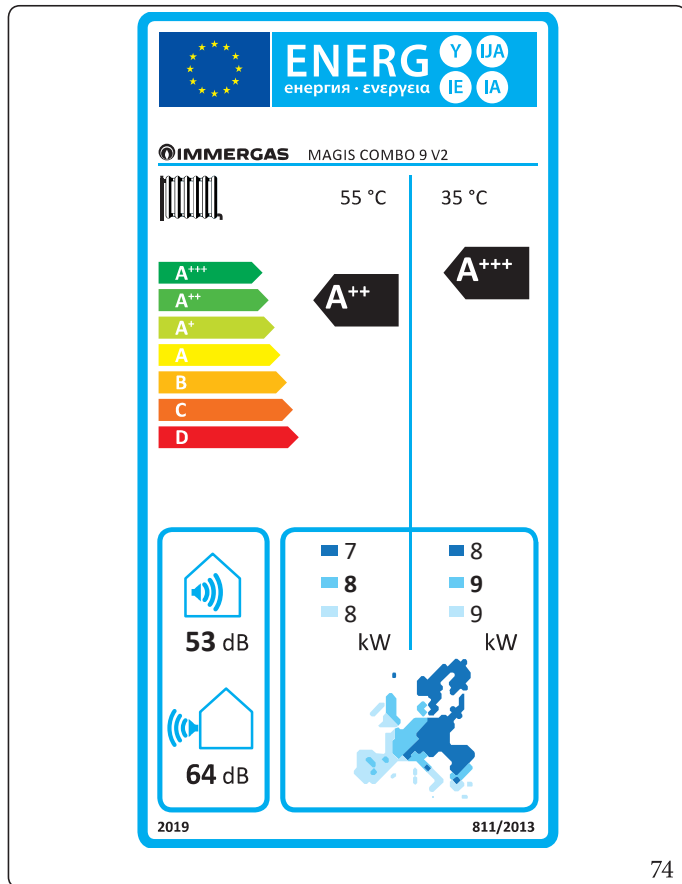

Low temperature (30/35)

Parameter	Value	Colder zones	Average zones	Hotter zones
Annual energy consumption for the central heating mode (Q_{HF})	kWh/year	5243	3949	1855
Room central heating seasonal efficiency (η_s)	η_s %	138	176	242
Nominal heat output	kW	8,00	9,00	9,00

Average temperature (47/55)

Parameter	Value	Colder zones	Average zones	Hotter zones
Annual energy consumption for the central heating mode (Q_{HF})	kWh/year	7223	5054	2709
Room central heating seasonal efficiency (η_s)	η_s %	93	128	155
Nominal heat output	kW	7,00	8,00	8,00

INSTALLER

USER

MAINTENANCE TECHNICIAN

TECHNICAL DATA

Average temperature table (47/55) average zones

Model	MAGISCOMBO9V2						
Air/water heat pump	yes	Low temperature heat pump				no	
Water/water heat pump	no	With additional central heating device				yes	
Brine/water heat pump	no	Mixed central heating device with heat pump:				yes	
The parameters are declared for average temperature application, except for low temperature heat pumps. The parameters for low temperature heat pumps are declared for low temperature application							
The parameters are declared for average climatic conditions							
Element	Symbol	Value	Unit	Element	Symbol	Value	Unit
Nominal heat output	$P_{nominale}$	8,00	kW	Room central heating seasonal energy efficiency	η_s	128	%
Central heating capacity declared with a partial load and indoor temperature equivalent to 20°C and outdoor temperature T_j				Performance coefficient declared with indoor temperature equivalent to 20°C and outdoor temperature T_j			
$T_j = -7^\circ\text{C}$	Pdh	7,1	kW	$T_j = -7^\circ\text{C}$	COPd	1,76	-
$T_j = +2^\circ\text{C}$	Pdh	4,3	kW	$T_j = +2^\circ\text{C}$	COPd	3,32	-
$T_j = +7^\circ\text{C}$	Pdh	2,8	kW	$T_j = +7^\circ\text{C}$	COPd	4,62	-
$T_j = +12^\circ\text{C}$	Pdh	2,6	kW	$T_j = +12^\circ\text{C}$	COPd	5,88	-
$T_j = \text{bivalent temperature}$	Pdh	7,1	kW	$T_j = \text{bivalent temperature}$	COPd	1,76	-
$T_j = \text{operating limit temperature}$	Pdh	4,9	kW	$T_j = \text{operating limit temperature}$	COPd	1,35	-
for air/water heat pumps: $T_j = -15^\circ\text{C}$ (se TOL < -20°C)	Pdh	0,0	kW	for air/water heat pumps: $T_j = -15^\circ\text{C}$ (se TOL < -20°C)	COPd	0	-
Bivalent temperature	T_{biv}	-7	°C	for air/water heat pumps: Operating limit temperature	TOL	-10	°C
Central heating capacity cycle intervals	Ppsych	0,0	kW	Cycle intervals efficiency	COPd	0	-
Degradation coefficient	Cdh	0,9	-	Water heating temperature operating limit	WTOL	0	°C
Different mode of energy consumption from the active mode				Additional heating appliance			
OFF mode	P_{OFF}	0,000	kW	Nominal heat output	P_{sup}	24,00	kW
Thermostat mode off	P_{TO}	0,010	kW	Type of energy supply voltage	FOSSIL FUEL		
Standby mode	P_{SB}	0,010	kW				
Guard heating mode	P_{CK}	0,000	kW				
Other items							
Capacity control	VARIABLE			For air/water heat pumps: nominal air output to outside	-	3960	m ³ /h
Indoor/outdoor sound level	L_{WA}	64	dB	For water or brine/water heat pumps: nominal flow of brine or water, outdoor heat exchanger	-	-	m ³ /h
Annual energy consumption	Q_{HE}	5054	kWh or GJ				
For mixed central heating appliances with a heat pump							
Stated load profile	XL			Water central heating energy efficiency	η_{wh}	86	%
Daily electrical power consumption	Q_{elec}	0,305	kWh	Daily fuel consumption	Q_{fuel}	22,14	kWh
Annual energy consumption	AEC	67	kWh	Annual fuel consumption	AFC	17	GJ
Contact information	Immergas S.p.A. via Cisa Ligure n.95						

4.7 PARAMETERS FOR FILLING IN THE PACKAGE FICHE

Should you wish to install an assembly starting from the Magis Combo V2 package, use the package fiche shown in (Fig. 77).

For correctly filling in, enter the figures into the specific spaces (as shown in the facsimile package fiche Fig. 76) found on the tables of paragraphs "Parameters to fill in the low temperature package fiche (30/35)", "Parameters to fill in the average temperature package fiche (47/55)".

The remaining values must be obtained from the technical data sheets of the products used to make up the assembly (e.g. solar devices, integration indoor unit, temperature controllers).

Use sheet (Fig. 77) "assemblies" related to the central heating function (e.g.: heat pump + temperature controller).



Since the product is standard supplied with a temperature controller, the package fiche must always be completed.

Facsimile for filling in the package fiche for room central heating systems.

Room central heating seasonal energy efficiency of the heat pump	<input type="text" value="'I'"/> %																														
Temperature control From temperature control board	<div style="border: 1px solid black; padding: 5px; width: fit-content; margin-bottom: 5px;"> Class I = 1 %, Class II = 2 %, Class III = 1.5 %, Class IV = 2 %, Class V = 3 %, Class VI = 4 %, Class VII = 3.5 %, Class VIII = 5 % </div> <input type="text" value="+"/> %																														
Supplementary boiler From boiler board	<div style="border: 1px solid black; padding: 5px; width: fit-content; margin-bottom: 5px;"> Seasonal central heating energy efficiency of the room (%) </div> $(\text{ } - \text{'I'}) \times \text{'II'} = - \text{ } \%$																														
<i>Solar contribution</i>																															
From the board of the solar device	<div style="border: 1px solid black; padding: 5px; width: fit-content; margin-bottom: 5px;"> Classification of the tank A* = 0.95, A = 0.91, B = 0.86, C = 0.83, D-G = 0.81 </div>																														
<div style="display: flex; justify-content: space-around; margin-bottom: 5px;"> <div style="border: 1px solid black; padding: 2px 5px; font-size: small;">Dimensions of the manifold (in m²)</div> <div style="border: 1px solid black; padding: 2px 5px; font-size: small;">Volume of the tank (in m³)</div> <div style="border: 1px solid black; padding: 2px 5px; font-size: small;">Efficiency of the manifold (in %)</div> </div> $(\text{'III'} \times \text{ } + \text{'IV'} \times \text{ }) \times 0.45 \times (\text{ } / 100) \times \text{ } = + \text{ } \%$	<input type="text" value="+"/> %																														
Room central heating seasonal energy efficiency of the assemble in average climate conditions	<input type="text" value=""/> %																														
Room central heating seasonal energy efficiency class of the assemble in average climate conditions	<div style="border: 1px solid black; padding: 10px; width: fit-content; margin: 0 auto;"> <table style="width: 100%; text-align: center; border-collapse: collapse;"> <tr> <td style="width: 10%;"><input type="checkbox"/></td> <td style="width: 10%;"><input type="checkbox"/></td> <td style="width: 10%;"><input type="checkbox"/></td> <td style="width: 10%;"><input type="checkbox"/></td> <td style="width: 10%;"><input type="checkbox"/></td> <td style="width: 10%;"><input type="checkbox"/></td> <td style="width: 10%;"><input type="checkbox"/></td> <td style="width: 10%;"><input type="checkbox"/></td> <td style="width: 10%;"><input type="checkbox"/></td> <td style="width: 10%;"><input type="checkbox"/></td> </tr> <tr> <td>G</td> <td>F</td> <td>E</td> <td>D</td> <td>C</td> <td>B</td> <td>A</td> <td>A⁺</td> <td>A⁺⁺</td> <td>A⁺⁺⁺</td> </tr> <tr> <td>< 30 %</td> <td>≥ 30 %</td> <td>≥ 34 %</td> <td>≥ 36 %</td> <td>≥ 75 %</td> <td>≥ 82 %</td> <td>≥ 90 %</td> <td>≥ 98 %</td> <td>≥ 125 %</td> <td>≥ 150 %</td> </tr> </table> </div>	<input type="checkbox"/>	<input type="checkbox"/>	<input type="checkbox"/>	<input type="checkbox"/>	<input type="checkbox"/>	<input type="checkbox"/>	<input type="checkbox"/>	<input type="checkbox"/>	<input type="checkbox"/>	<input type="checkbox"/>	G	F	E	D	C	B	A	A⁺	A⁺⁺	A⁺⁺⁺	< 30 %	≥ 30 %	≥ 34 %	≥ 36 %	≥ 75 %	≥ 82 %	≥ 90 %	≥ 98 %	≥ 125 %	≥ 150 %
<input type="checkbox"/>	<input type="checkbox"/>	<input type="checkbox"/>	<input type="checkbox"/>	<input type="checkbox"/>	<input type="checkbox"/>	<input type="checkbox"/>	<input type="checkbox"/>	<input type="checkbox"/>	<input type="checkbox"/>																						
G	F	E	D	C	B	A	A⁺	A⁺⁺	A⁺⁺⁺																						
< 30 %	≥ 30 %	≥ 34 %	≥ 36 %	≥ 75 %	≥ 82 %	≥ 90 %	≥ 98 %	≥ 125 %	≥ 150 %																						
Room central heating seasonal energy efficiency in colder and hotter climate conditions																															
Colder: <input type="text" value=""/> - 'V' = <input type="text" value=""/> %	Hotter: <input type="text" value=""/> + 'VI' = <input type="text" value=""/> %																														
<p><i>The energy efficiency of the set of products indicated in this sheet may not reflect the actual energy efficiency after installation since such efficiency is affected by additional factors, such as the heat loss in the distribution system and the size of the products compared to the size and features of the building.</i></p>																															

INSTALLER

USER

MAINTENANCE TECHNICIAN

TECHNICAL DATA

Parameters to fill in the low temperature package fiche (30/35)

Magis Combo 4 V2

Parameter	Colderzones	Averagezones	Hotterzones
	■	■	■
"I"	140	181	235
"II"	*	*	*
"III"	6,68	5,35	5,35
"IV"	2,61	2,09	2,09

Magis Combo 6 V2

Parameter	Colderzones	Averagezones	Hotterzones
	■	■	■
"I"	140	181	236
"II"	*	*	*
"III"	5,57	4,45	4,77
"IV"	2,18	1,74	1,87

Magis Combo 9 V2

Parameter	Colderzones	Averagezones	Hotterzones
	■	■	■
"I"	138	176	242
"II"	*	*	*
"III"	3,34	2,97	2,97
"IV"	1,31	1,16	1,16

* to be determined according to Regulation 811/2013 and transient calculation methods as per Notice of the European Community no. 207/2014.

Parameters to fill in the average temperature package fiche (47/55)

Magis Combo 4 V2

Parameter	Colderzones	Averagezones	Hotterzones
	■	■	■
"I"	96	128	150
"II"	*	*	*
"III"	6,68	5,35	5,35
"IV"	2,61	2,09	2,09

Magis Combo 6 V2

Parameter	Colderzones	Averagezones	Hotterzones
	■	■	■
"I"	93	130	151
"II"	*	*	*
"III"	5,57	4,45	4,77
"IV"	2,18	1,74	1,87

Magis Combo 9 V2

Parameter	Colderzones	Averagezones	Hotterzones
	■	■	■
"I"	93	128	155
"II"	*	*	*
"III"	3,82	3,34	3,34
"IV"	1,49	1,31	1,31

* to be determined according to Regulation 811/2013 and transient calculation methods as per Notice of the European Community no. 207/2014.

Room central heating seasonal energy efficiency of the heat pump

%

Temperature control
From temperature control board

Class I = 1 %, Class II = 2 %,
Class III = 1.5 %, Class IV = 2 %,
Class V = 3 %, Class VI = 4 %,
Class VII = 3.5 %, Class VIII = 5 %

+ %

Supplementary boiler
From boiler board

Seasonal central heating energy efficiency of the room (%)

(- _____) x _____ = - %

Solar contribution

From the board of the solar device

Dimensions of the manifold (in m²)

Volume of the tank (in m³)

Efficiency of the manifold (in %)

Classification of the tank
A* = 0.95, A = 0.91,
B = 0.86, C = 0.83,
D-G = 0.81

(___ x + ___ x) x 0.45 x (/ 100) x = + %

Room central heating seasonal energy efficiency of the assemble in average climate conditions

%

Room central heating seasonal energy efficiency class of the assemble in average climate conditions

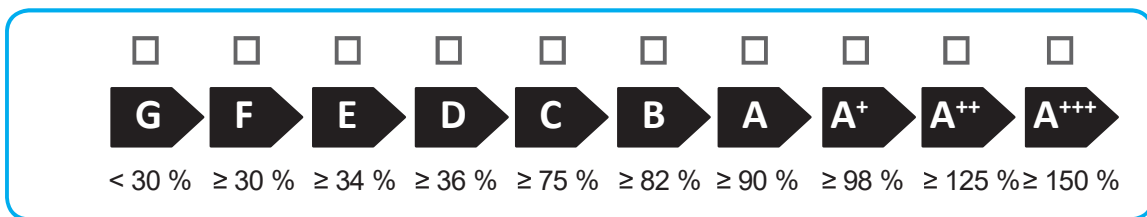

Room central heating seasonal energy efficiency in colder and hotter climate conditions

Colder: - ___ = %

Hotter: + ___ = %

The energy efficiency of the set of products indicated in this sheet may not reflect the actual energy efficiency after installation since such efficiency is affected by additional factors, such as the heat loss in the distribution system and the size of the products compared to the size and features of the building.



This instruction booklet is made of ecological paper.

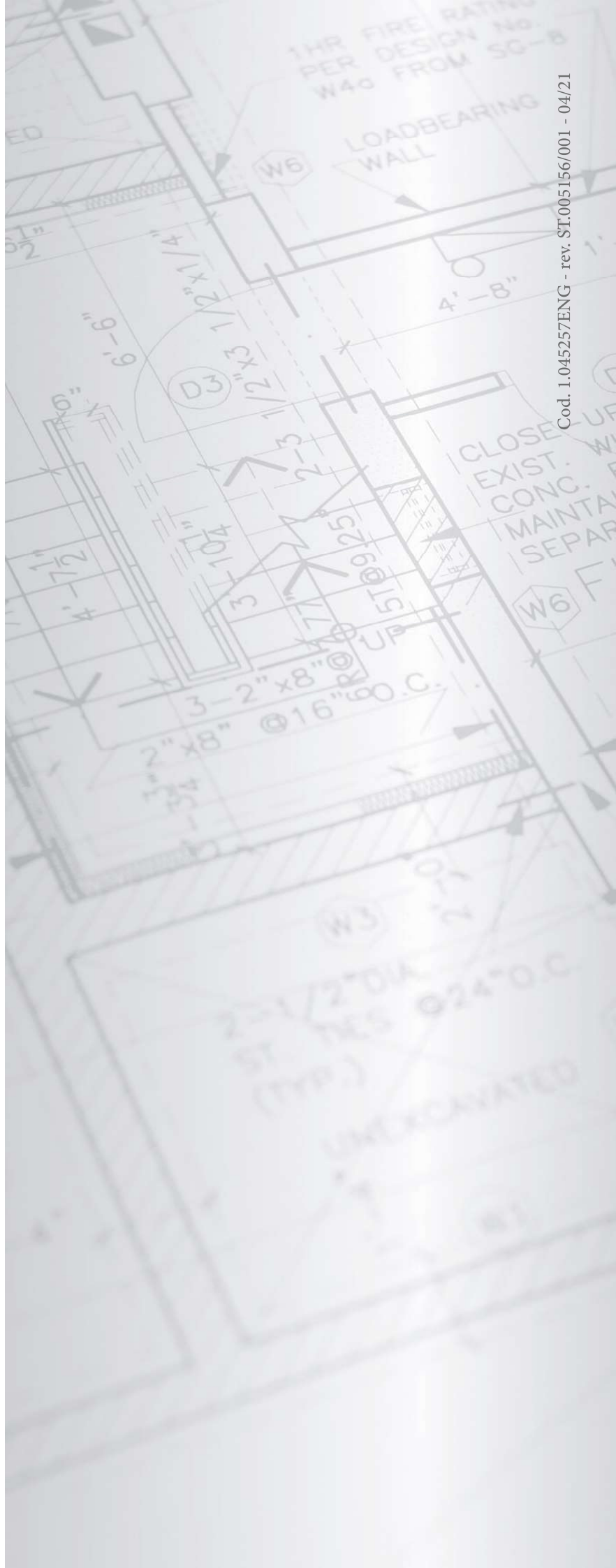

Cod. 1.045257ENG - rev. ST.005156/001 - 04/21

immergas.com

Immergas S.p.A.
42041 Brescello (RE) - Italy
Tel. 0522.689011
Fax 0522.680617



IMMERGAS
IMMERGAS SPA - ITALY
CERTIFIED COMPANY
UNI EN ISO 9001:2015

Design, manufacture and post-sale assistance of gas boilers, gas water heaters and related accessories